

**PanelTECH<sup>®</sup>**



## FLASHINGS & ACCESSORIES

for sandwich panels





# TABLE OF CONTENTS

## INTRODUCTION

### COMPREHENSIVE SYSTEM OF FLASHINGS ..... 7

#### WALL PANEL FLASHINGS

Socle drip caps (001, 003 B, 004).....	10
wall drip caps ( 005, 006, 007, 008, 009).....	11
internal groundsill flashing (010, 011, 012, 013) .....	12
External angle sections (015, 016).....	14
External corner profiles (017, 018, 019) .....	14
Internal corner profile (020, 021) .....	15
Rounded corners (022, 023, 024) .....	16
Channel section (025) .....	17
Flat bar (026) .....	17
Panel joint masking frame (027, 028, 029) .....	18
Gate opening masking frames (036, 037 B, 039 B, 046, 047, 049) .....	19
Window opening masking frames (051, 052, 053, 054 B, 055 B, 056 B, 057 B, 058 B, 059 B) ....	21
Starting lists (075, 076, 077) .....	24

#### ROOF PANEL FLASHINGS

Roof ridges (101, 103) .....	28
Verges of the shed roof (104, 105, 106, 107).....	29
Roof masking frames (109) .....	31
Gutter drip cap (110) .....	31
Snow hurdle (111) .....	31
Attic (112, 113).....	32
Slope masking frames (114, 115, 116, 117B).....	33
Drip caps (118, 119).....	34
List of slope masking frame (121).....	35
Gutter Z-bars (130, 131) .....	35
Gutter channel (150).....	36

#### ACCESSORIES

102 flashing .....	40
UD42 ridge roof seal .....	40
Z42 roof end cap .....	40
SU washer .....	40
Tapes .....	41
Sealing compounds and assembly foams .....	42
Self-drilling and self-tapping fasteners, precision drills, self-drilling screws .....	43
Clips, blind rivets, caps, masking clips .....	44



# INTRODUCTION

Founded in 1989, Paneltech has been developing high-end products for the Polish construction industry. For over 30 years, Paneltech has combined reliability and highest product quality with timely services and deliveries. We have achieved this by employing our extensive experience and investing in the development of state of the art process lines. This is why, today, we are proud to say that we are one of the leaders on the Polish market of sandwich panels. We have received the support and trust of many clients, both in and outside the country. Our products are exported to nearly 30 countries from all over the world.

Paneltech offers the modern and comprehensive Light Cladding System with sandwich panels. Our regular offer includes the following sandwich panels:

- with the PUR/PIR core,
- with the EPS core,
- with the mineral wool core.

Paneltech has its own machine park, research laboratory and the experienced quality control department thank to which manufactures itself highest-quality sandwich panels, industrial doors and EPS. Apart from these, Paneltech offers also facade cassettes, PIR Soft insulation panels, EPS profiles, EPS roofing paper, XPS, aluminum and PVC joinery, stainless steel products and Hormann gates and reloading systems.



# COMPREHENSIVE SYSTEM OF FLASHINGS

Paneltech company offers flashings made of different types of steel:

- galvanized, without coating, thickness 0,75 mm 1,00 mm, 1,50 mm and 2,00 mm;
- galvanized with polyester coating 25  $\mu\text{m}$ , in standard available RAL colours, steel thickness 0,50 mm;
- galvanized with polyester coating 25  $\mu\text{m}$ , in colours RAL 7016, 7024, 7035, 8017, 9008, 9006, 9007 and 9010, steel thickness 0,75 mm;
- galvanized with polyester coating 25  $\mu\text{m}$ , in RAL 9010, steel thickness 1,50 mm;
- galvanized with polyester coating 35  $\mu\text{m}$  in available RAL colours, steel thickness 0,50 mm;
- galvanized with foodsafe coating, steel thickness 0,50 mm;
- stainless acid-proof steel, mark 1.4301, thickness 0,50 mm; 0,80 mm and 1,50 mm.

Paneltech flashings are available in length:

- standard: 3,00 m, 5,00 m and 6,00 m;
- nonstandard: 0,10 m - 8,00 m (depends on flashing's form and steel thickness).

Flashings made of 0.80 and 1.50 mm stainless steel sheet metal and 2.00 mm unpainted zinc-plated sheet metal are manufactured in lengths of up to 3 m.

Price of the flashings depends on:

- steel type and thickness;
- type of the coating;
- flashing length and form;
- volume size of the order.

Flashings can be powder painted to any RAL colour.

## TECHNOLOGICAL CAPABILITIES OF MANUFACTURED FLASHINGS

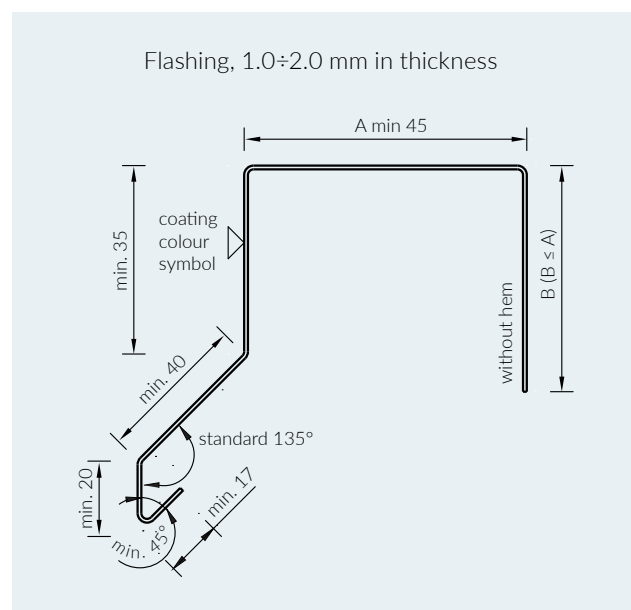
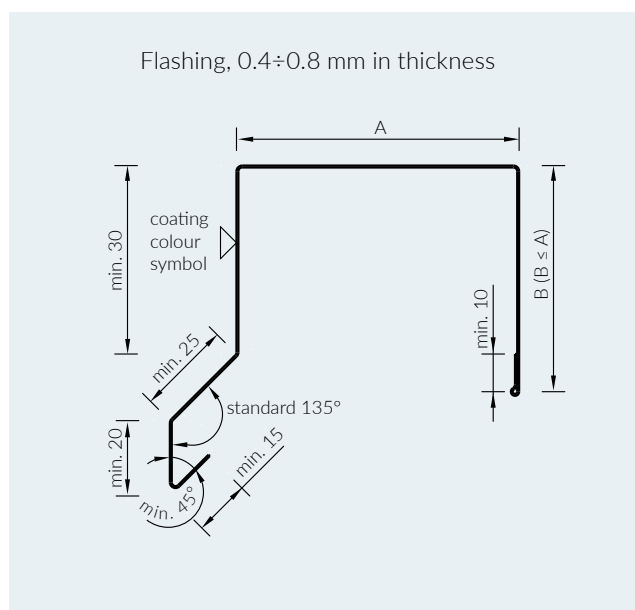





# WALL PANEL FLASHINGS

FLASHING 001 - SOCLE DRIP CAP

symbol / thickness	A	B	C	D	$\alpha^\circ$	E	L	area
001/40	15	40	25	40	170	54	3000 5000 6000	135
001/50	25	40	25	40	170	64		145
001/60	35	40	25	40	170	74		155
001/80	55	40	25	40	170	94		175
001/100	75	40	25	40	170	114		195
001/120	95	40	25	40	170	134		215
001/140	115	40	25	40	170	154		235
001/150	125	40	25	40	170	164		245
001/160	135	40	25	40	170	174		255
001/180	155	40	25	40	170	194		275
001/200	175	40	25	40	170	214		295

Typical steel sheet thickness 0,50 mm  
 Untypical steel sheet thickness 0,50 mm or 0,75 mm  
 001 / A ..... / B ..... / C ..... / D ..... /  $\alpha$  .....

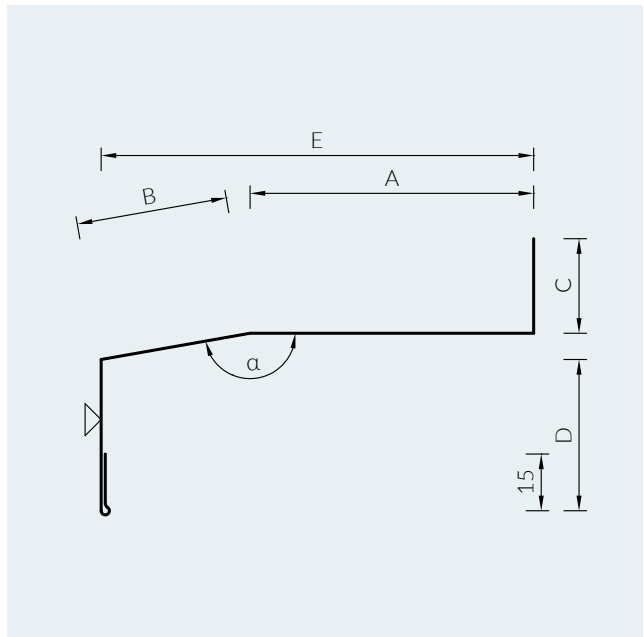

FLASHING 003 B - SOCLE DRIP CAP

symbol	A	B	C	$\alpha^\circ$	L	area
003B	30	30	20	96	3000	95

Typical steel sheet thickness 0,50 mm  
 Untypical steel sheet thickness 0,50 mm or 0,75 mm  
 003B / A ..... / B ..... / C ..... /  $\alpha$  .....

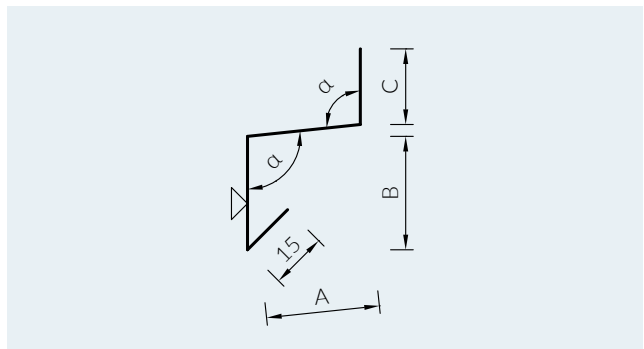

FLASHING 004 - SOCLE DRIP CAP

symbol / thickness	A	B	$\alpha^\circ$	L	area
004/40	40	40	135	3000 5000 6000	125
004/50	50	40	135		135
004/60	60	40	135		145
004/80	80	40	135		165
004/100	100	40	135		185
004/120	120	40	135		205
004/140	140	40	135		225
004/150	150	40	135		235
004/160	160	40	135		245
004/180	180	40	135		265
004/200	200	40	135		285

Typical steel sheet thickness 0,50 mm  
 Untypical steel sheet thickness 0,50 mm or 0,75 mm  
 004 / A ..... /  $\alpha$  .....

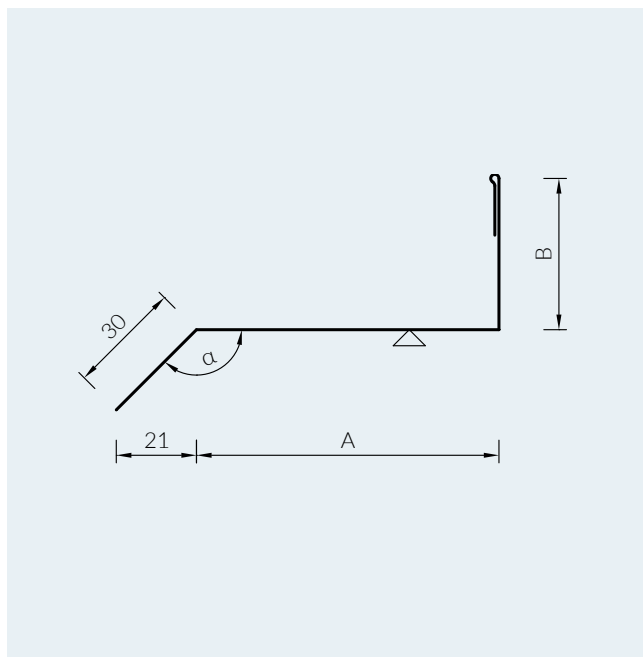

FLASHING 005 - WALL DRIP CAP

symbol	A	B	C	L	area
005/40	40	25	40	3000	135
005/60	40	25	60		155
005/80	40	25	80	5000	175
005/100	40	25	100	6000	195

Typical steel sheet thickness 0,50 mm

Untypical steel sheet thickness 0,50 mm or 0,75 mm

005 / A ..... / B ..... / C .....

\* for dimension B=25

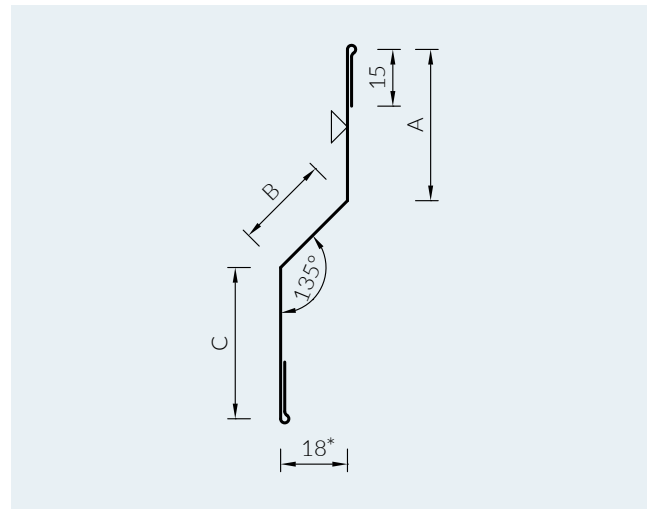

FLASHING 006 - WALL DRIP CAP

symbol	A	B	C	L	area
006/40	40	25	40	3000	140
006/60	40	25	60		160
006/80	40	25	80	5000	180
006/100	40	25	100	6000	200

Typical steel sheet thickness 0,50 mm

Untypical steel sheet thickness 0,50 mm or 0,75 mm

006 / A ..... / B ..... / C ..... / a .....

\* for dimension B=25

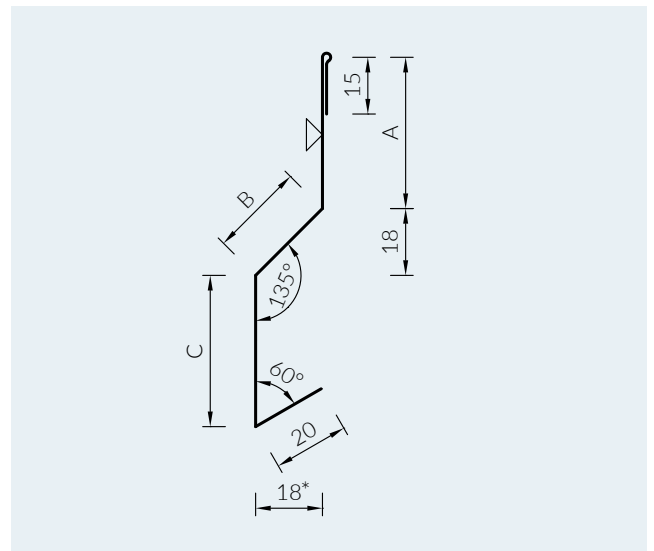

FLASHING 007 - WALL DRIP CAP

symbol	L	area
007	3000	140
	5000	
	6000	

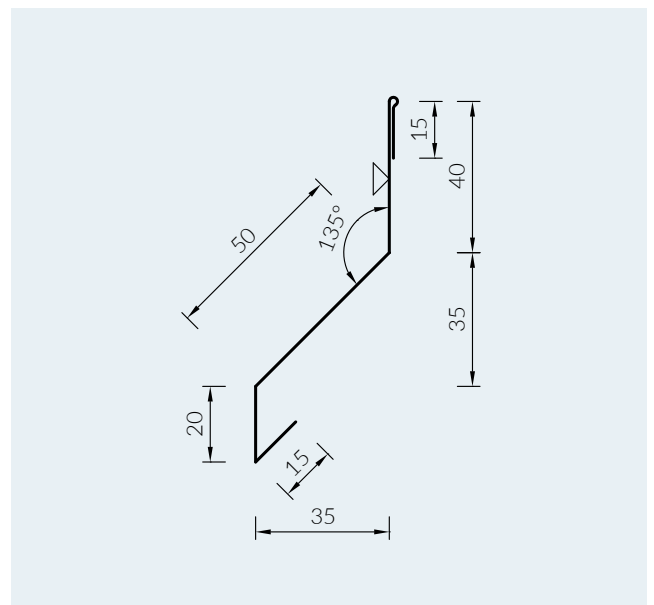

**FLASHING 008 - DRIP CAP**

symbol	A	B	$\alpha^\circ$	L	area
008/40	40	40	135	3000	135
				5000	
				6000	

Typical steel sheet thickness 0,50 mm  
 Untypical steel sheet thickness 0,50 mm or 0,75 mm  
 008 / A ..... / B ..... /  $\alpha$  .....  
 \* for dimension B=25

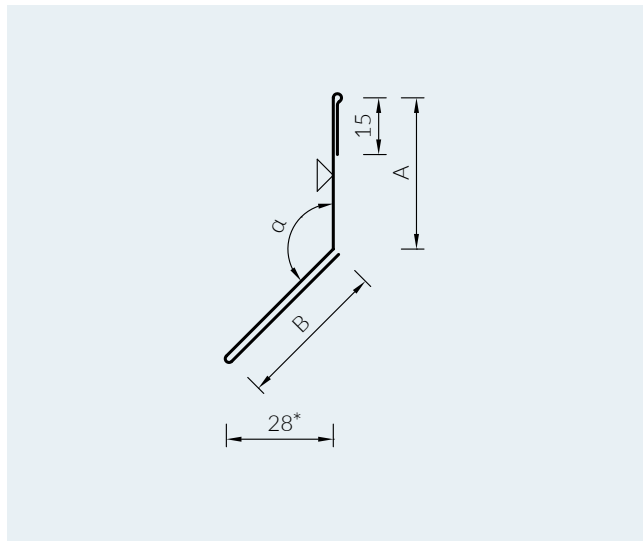

**FLASHING 009 - WALL DRIP CAP**

symbol	A	B	C	$\alpha^\circ$	L	area
009/50	50	30	30	100	3000	140
009/100	100	30	30	100	5000	190
009/150	150	30	30	100	6000	240

Typical steel sheet thickness 0,50 mm  
 Untypical steel sheet thickness 0,50 mm or 0,75 mm  
 009 / A ..... / B ..... / C ..... /  $\alpha$  .....

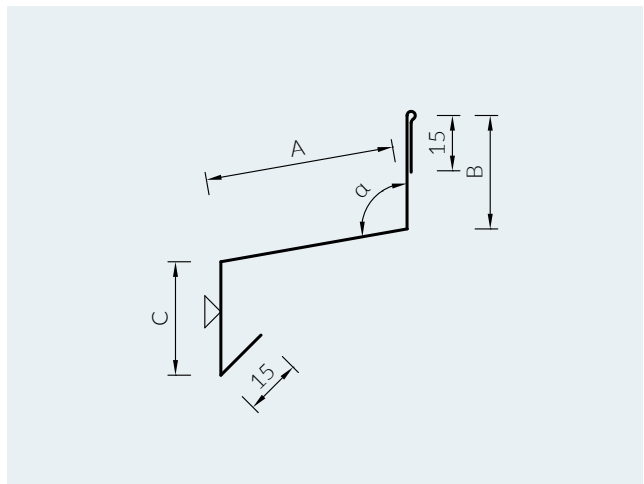

**FLASHING 010 - INTERNAL GROUND SILL FLASHING**

symbol	A	B	$\alpha^\circ$	C	L	area
010/50	50	50	135	71	3000 5000 6000	161
010/80	80	80	135	114		204
010/100	100	100	135	142		232
010/120	120	120	135	170		260

Typical steel sheet thickness 0,50 mm  
 Untypical steel sheet thickness 0,50 mm or 0,75 mm  
 010 / A ..... / B ..... / C ..... /  $\alpha$  .....

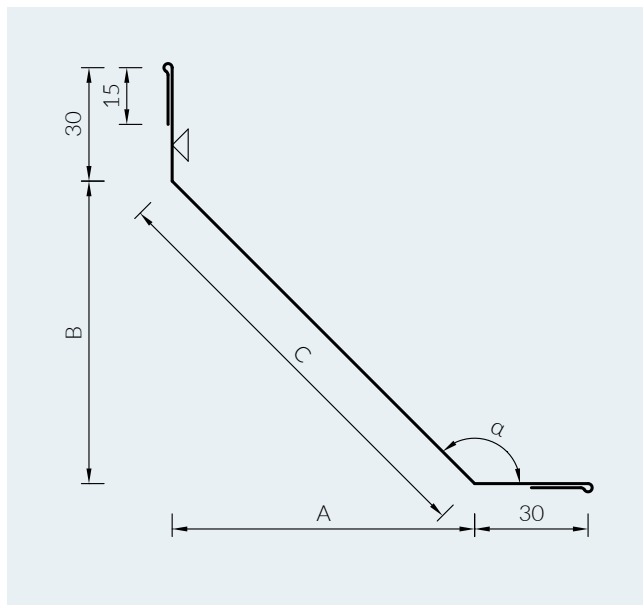

**FLASHING 011 - INTERNAL GROUNDSILL FLASHING**

symbol	A	B	$\alpha^\circ$	C	D	L	area
011/80	80	80	105	83	59	3000 5000	232
011/120	120	120	105	125	88	6000	303

Typical steel sheet thickness 0,50 mm

Unotypical steel sheet thickness 0,50 mm or 0,75 mm

011 / A ..... / B ..... / C ..... /  $\alpha$  .....

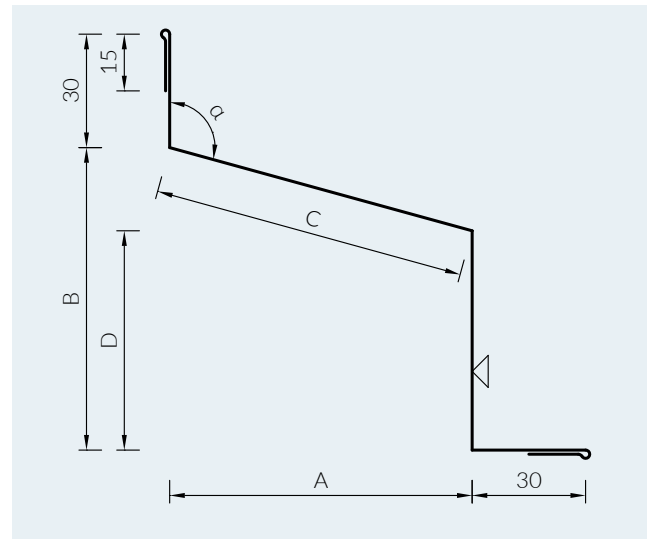

**FLASHING 012 - FLASHING OF INTERNAL GROUNDSILL AND WINDOW OPENING**

symbol	A	B	$\alpha^\circ$	L	area
012	50	20	135	3000 5000 6000	160

Typical steel sheet thickness 0,50 mm

Unotypical steel sheet thickness 0,50 mm or 0,75 mm

012 / A ..... / B ..... /  $\alpha$  .....

\* for dimension B=20

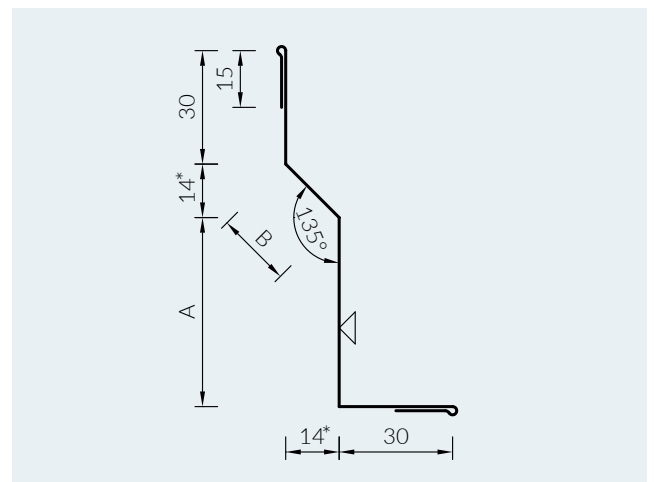

**FLASHING 013 - INTERNAL GROUNDSILL FLASHING**

symbol	A	B	C	L	area
013	70	50	20	3000 5000 6000	250

Typical steel sheet thickness 0,50 mm

Unotypical steel sheet thickness 0,50 mm or 0,75 mm

013 / A ..... / B ..... / C .....

\* for dimension B=20

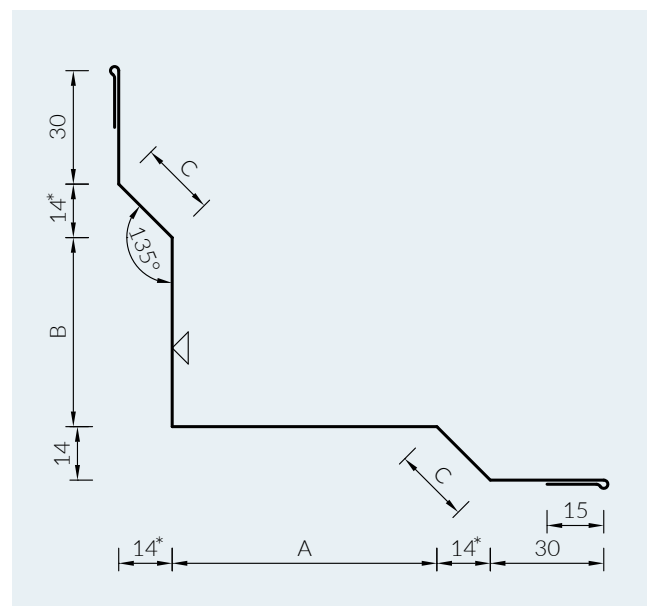

FLASHING 015 - EQUILATERAL EXTERNAL ANGLE SECTION

symbol	A	$\alpha^\circ$	L	area
015/25	25	90	3000 5000 6000	80
015/30	30	90		90
015/40	40	90		110
015/50	50	90		130
015/100	100	90		230
015/150	150	90		330

Typical steel sheet thickness 0,50 mm  
 Untypical steel sheet thickness 0,50 mm or 0,75 mm  
 015 / A ..... /  $\alpha$  .....

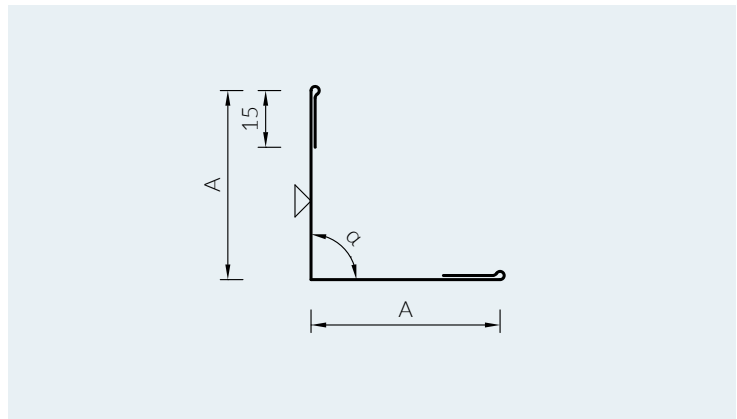

FLASHING 016 - EXTERNAL ANGLE SECTION

symbol	A	B	$\alpha^\circ$	L	area
016/50/70	50	70	90	3000	150
016/50/100	50	100	90	5000	180
016/50/150	50	150	90	6000	230

Typical steel sheet thickness 0,50 mm  
 Untypical steel sheet thickness 0,50 mm or 0,75 mm  
 016 / A ..... / B ..... /  $\alpha$  .....

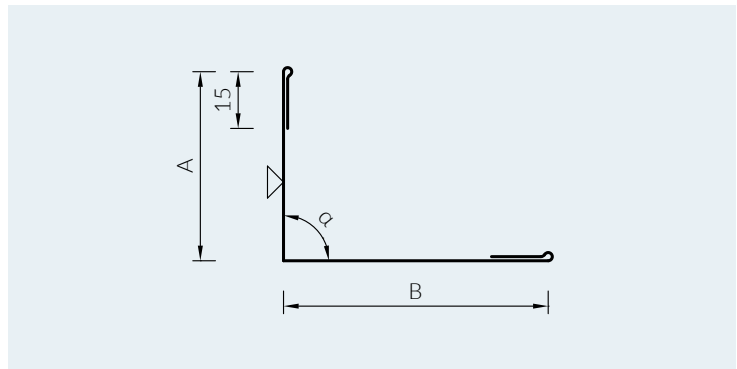

FLASHING 017 - EXTERNAL ANGLE SECTION

symbol	panel thk.	A	B	C	L	area
017/100	-	100	31	139	3000 5000 6000	324
017/120	40	120	41	159		364
017/160	80	160	61	199		444
017/180	100	180	71	219		484
017/200	120	200	81	239		524
017/240	160	240	101	279		604
017/280	200	280	121	319		684
017/330	-	330	146	369		784

Typical steel sheet thickness 0,50 mm  
 Untypical steel sheet thickness 0,50 mm or 0,75 mm  
 017 / A .....

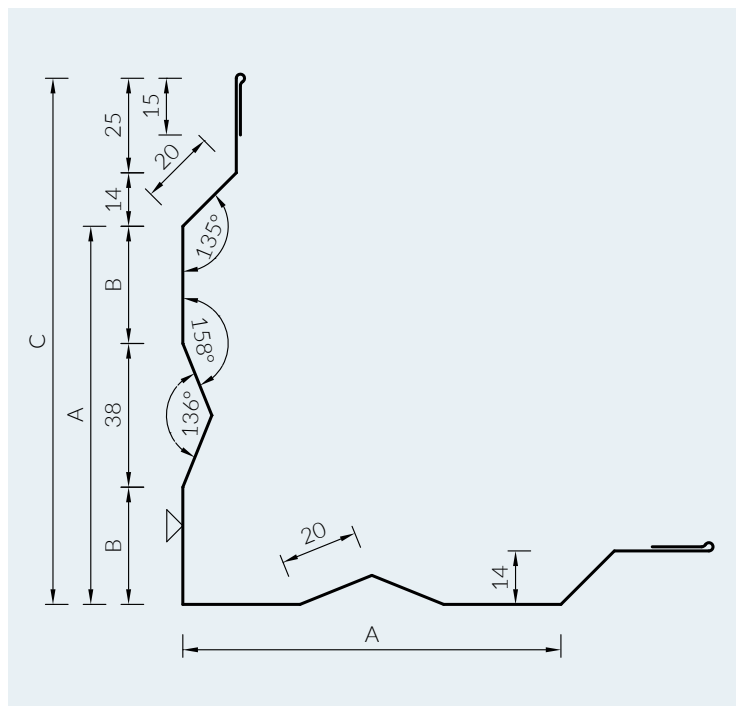

FLASHING 018 - EXTERNAL ANGLE SECTION

symbol	panel thk.	A	C	L	area
018/100	-	100	139	3000 5000 6000	320
018/120	40	120	159		360
018/140	60	140	179		400
018/160	80	160	199		440
018/180	100	180	219		480
018/200	120	200	239		520

Typical steel sheet thickness 0,50 mm

Unotypical steel sheet thickness 0,50 mm or 0,75 mm

018 / A .....

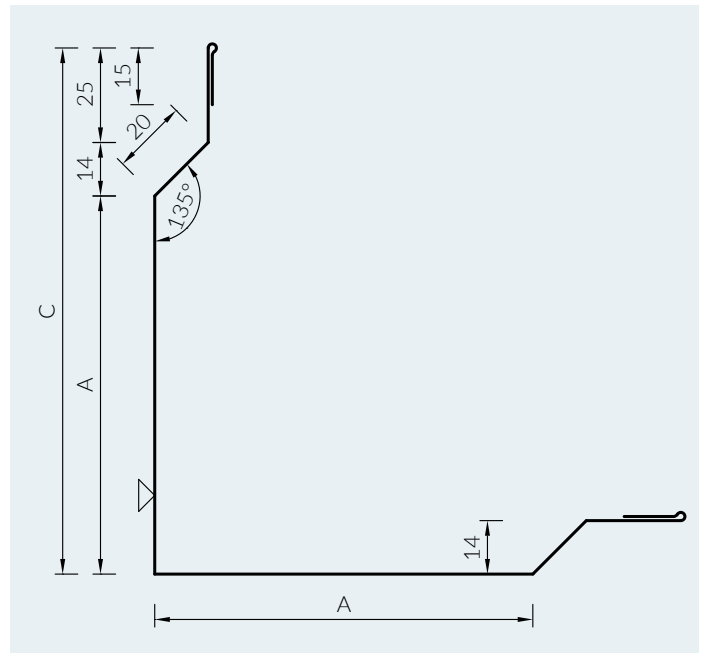

FLASHING 019 - EXTERNAL ANGLE SECTION

symbol	panel thk.	A	C	L	area
019/100	-	100	125	3000 5000 6000	320
019/120	40	120	145		360
019/140	60	140	165		400
019/160	80	160	185		440
019/180	100	180	205		480
019/200	120	200	225		520

Typical steel sheet thickness 0,50 mm

Unotypical steel sheet thickness 0,50 mm or 0,75 mm

019 / A .....

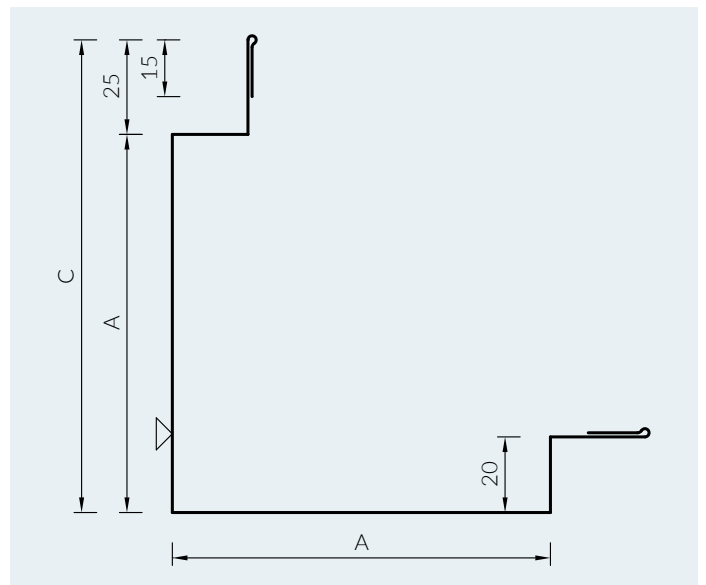

FLASHING 020 - EQUILATERAL INTERNAL CORNER PROFILE

symbol	A	$\alpha^\circ$	L	area
020/25	25	90	3000	80
020/30	30	90		90
020/40	40	90		110
020/50	50	90	3000	130
020/100	100	90	5000	230
020/150	150	90	6000	330

Typical steel sheet thickness 0,50 mm

Unotypical steel sheet thickness 0,50 mm or 0,75 mm

020 / A ..... /  $\alpha$  .....

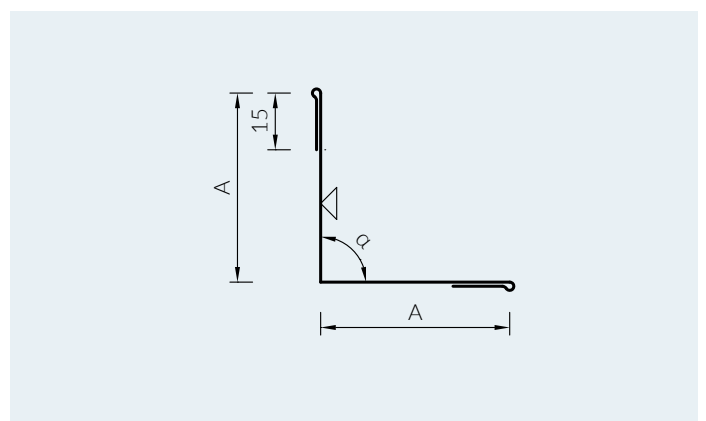

FLASHING 021 - INTERNAL ANGLE SECTION

symbol	A	B	L	area
021/50/70	50	70	3000	150
021/50/100	50	100	5000	180
021/50/150	50	150	6000	230

Typical steel sheet thickness 0,50 mm  
 Untypical steel sheet thickness 0,50 mm or 0,75 mm  
 021 / A ..... / B ..... / a .....

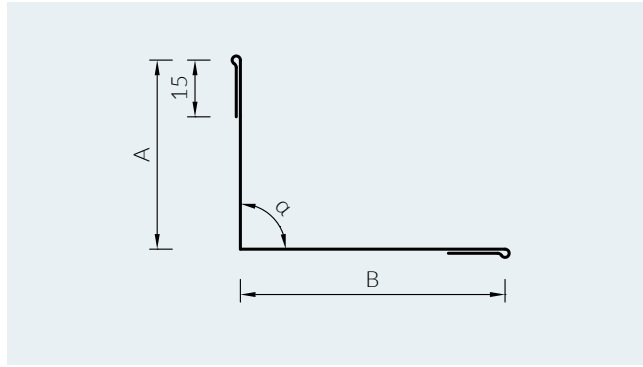

FLASHING 022 - ROUNDED CORNER (PANEL – PANEL)

symbol	L	area
022	3000	175
	5000	
	6000	

Typical steel sheet thickness 0,50 mm

symbol	L	area
022 /N-0,50	3000	175
	5000	
	6000	

Stainless steel thickness 0,50 mm

symbol	L	area
022 /N-0,75	3000	175

Stainless steel flashing, thickness 0,75 mm

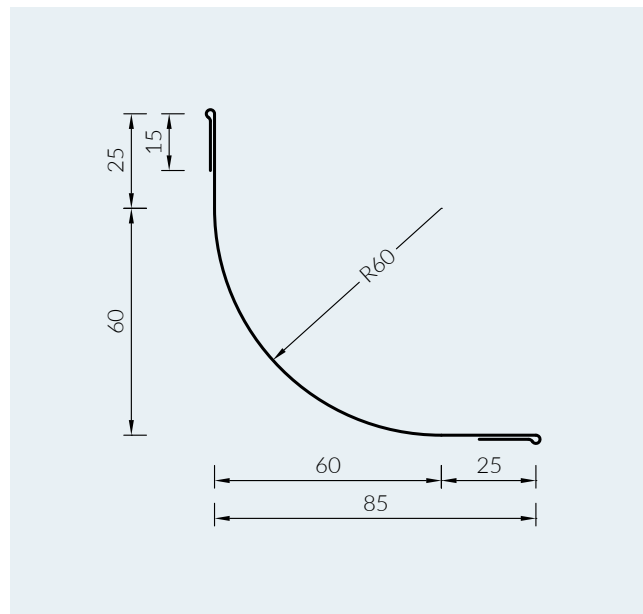

FLASHING 023 - ROUNDED CORNER (PANEL – TILE)

symbol	L	area
023 /N-0,50	3000	190
	5000	
	6000	

Stainless steel thickness 0,50 mm

symbol	L	area
023 /N-0,75	3000	190

Stainless steel flashing, thickness 0,75 mm

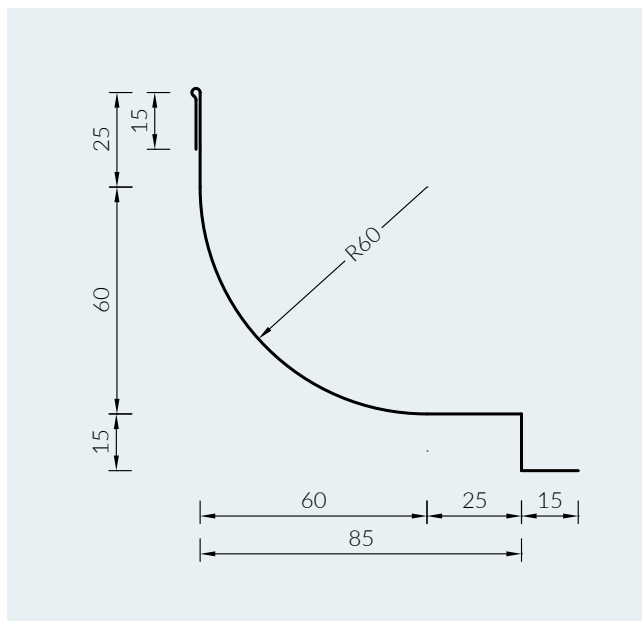



**FLASHING 024 - ROUNDED CORNER (PANEL – CONCRETE)**

symbol	L	area
024 /N-0,50	3000	175
	5000	
	6000	

Stainless steel thickness 0,50 mm

symbol	L	area
024 /N-0,75	3000	175

Stainless steel flashing, thickness 0,75 mm

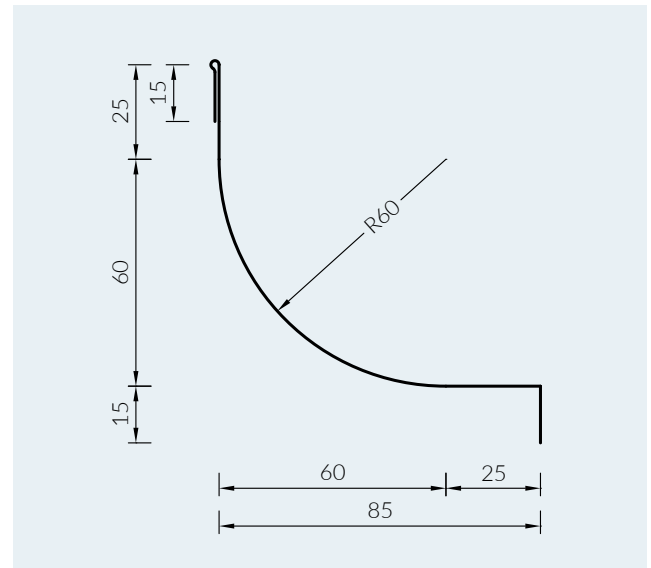

**FLASHING 025 -CHANNEL SECTION**

symbol	panel thk.	A	B	L	area
025/40	40	44	40	3000 5000 6000	154
025/50	50	54	40		164
025/60	60	64	40		174
025/80	80	84	40		194
025/100	100	104	40		214
025/120	120	124	40		234
025/140	140	144	40		254
025/150	150	154	40		264
025/160	160	164	40		274
025/180	180	184	40		294
025/200	200	204	40	314	

Typical steel sheet thickness 0,50 mm

Unypical steel sheet thickness 0,50 mm or 0,75 mm

025 / A ..... / B .....

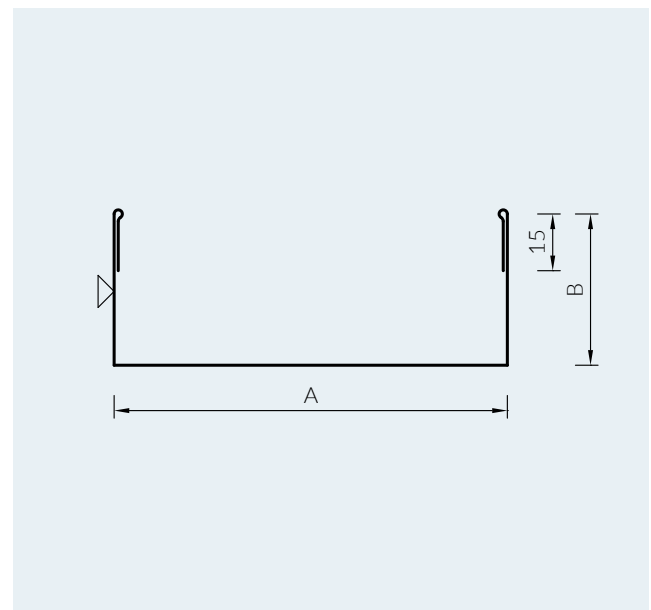

**FLASHING 026 - FLAT BAR**

symbol	A	L	area
026/50	50	3000 5000 6000	80
026/80	80		110
026/100	100		130
026/150	150		180

Typical steel sheet thickness 0,50 mm

Unypical steel sheet thickness 0,50 mm or 0,75 mm

026 / A .....

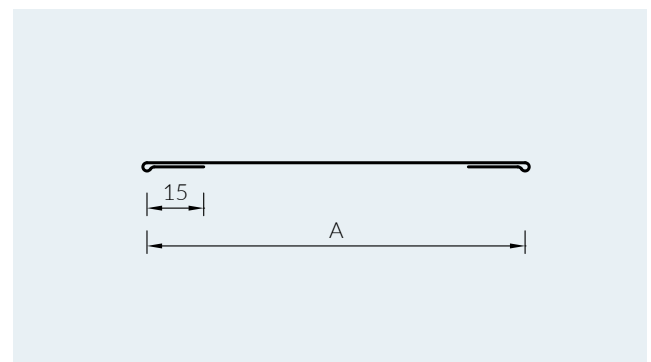

FLASHING 027 - PANEL JOINT MASKING FRAME

symbol	A	B	C	L	area
027/75	76	19	153	3000 5000 6000	198
027/100	100	31	178		222
027/120	120	41	198		242
027/140	140	51	218		262
027/160	160	61	238		282
027/180	180	71	258		302
027/200	200	81	278		322

Typical steel sheet thickness 0,50 mm  
 Untypical steel sheet thickness 0,50 mm or 0,75 mm  
 027 / A .....

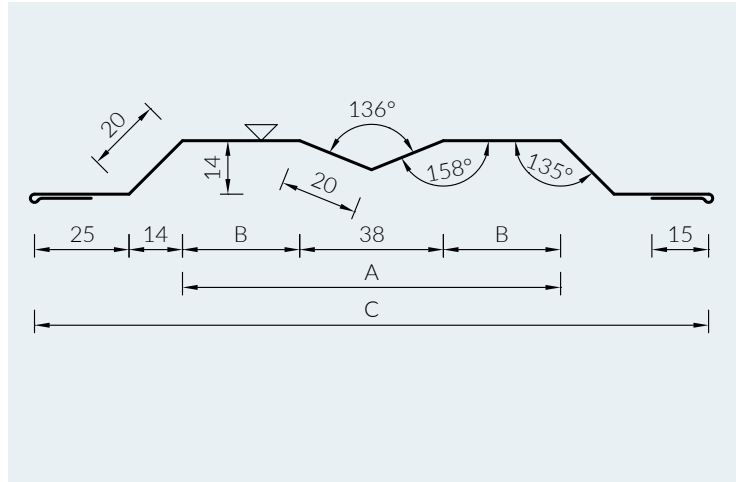

FLASHING 028 - PANEL JOINT MASKING FRAME

symbol	A	C	L	area
028/50	50	128	3000 5000 6000	170
028/75	75	153		195
028/100	100	178		220
028/120	120	198		240
028/140	140	218		260
028/160	160	238		280

Typical steel sheet thickness 0,50 mm  
 Untypical steel sheet thickness 0,50 mm or 0,75 mm  
 028 / A .....

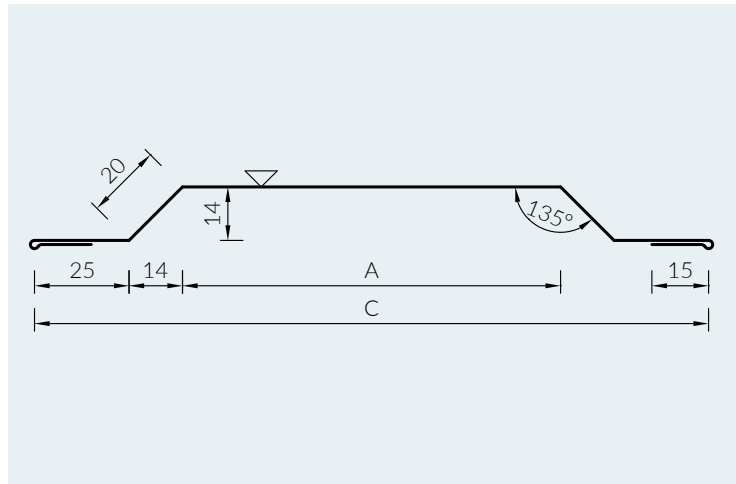

FLASHING 029 - PANEL JOINT MASKING FRAME

symbol	A	C	L	area
029/50	50	150	3000	170
029/75	75	125		195
029/100	100	150	3000	220
029/120	120	170		240
029/140	140	190	5000	260
029/160	160	210		280

Typical steel sheet thickness 0,50 mm  
 Untypical steel sheet thickness 0,50 mm or 0,75 mm  
 029 / A .....

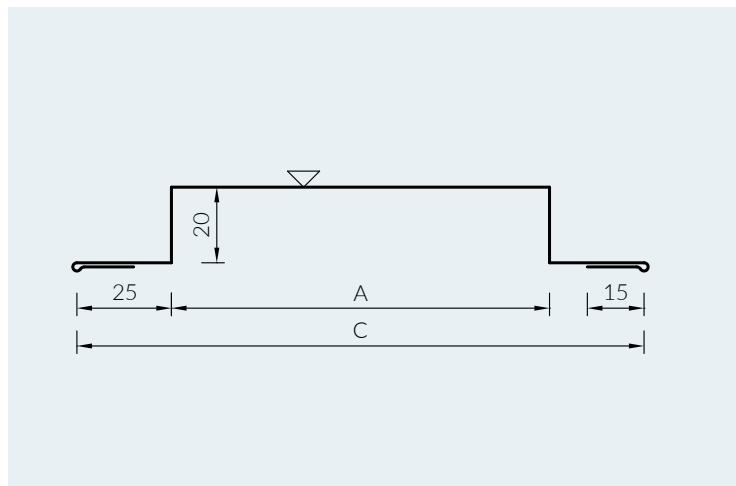

**FLASHING 036 - GATE OPENING MASKING FRAME**

symbol	G	A	B	C	L	area
036/120	120	124	50	30	3000 5000 6000	219
036/140	140	144	50	30		239
036/160	160	164	50	30		259
036/180	180	184	50	30		279
036/200	200	204	50	30		299
036/220	220	224	50	30		319
036/240	240	244	50	30		339
036/260	260	264	50	30		359

Typical steel sheet thickness 0,50 mm

Untypical steel sheet thickness 0,50 mm or 0,75 mm

036 / G ..... / B ..... / C .....

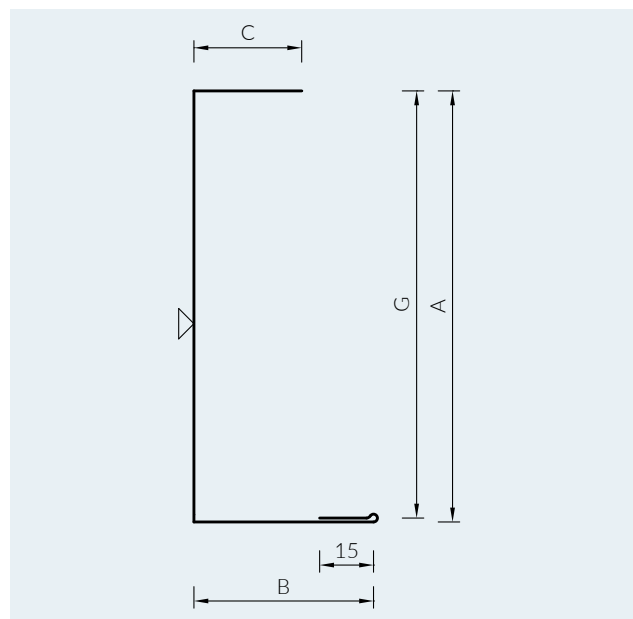

**FLASHING 037 B - GATE OPENING MASKING FRAME**

symbol	G	A	B	C	L	area
037B/120	120	136	50	30	3000 5000 6000	276
037B/140	140	156	50	30		296
037B/160	160	176	50	30		316
037B/180	180	196	50	30		336
037B/200	200	216	50	30		356
037B/220	220	236	50	30		376
037B/240	240	256	50	30		396
037B/260	260	276	50	30		416

Typical steel sheet thickness 0,50 mm

Untypical steel sheet thickness 0,50 mm or 0,75 mm

037B / G ..... / B ..... / C .....

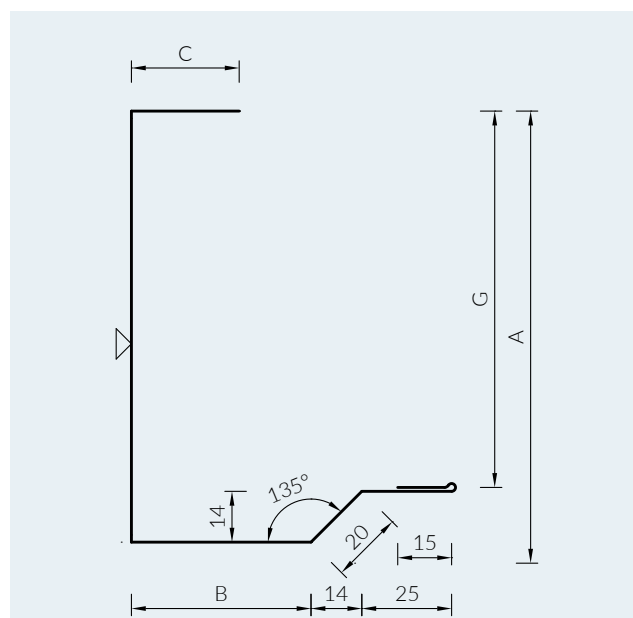

**FLASHING 039 B - GATE OPENING MASKING FRAME**

symbol	G	A	B	C	L	area
039B/120	120	142	50	30	3000 5000 6000	282
039B/140	140	162	50	30		302
039B/160	160	182	50	30		322
039B/180	180	202	50	30		342
039B/200	200	222	50	30		362
039B/220	220	242	50	30		382
039B/240	240	262	50	30		402
039B/260	260	282	50	30		422

Typical steel sheet thickness 0,50 mm

Untypical steel sheet thickness 0,50 mm or 0,75 mm

039B / G ..... / B ..... / C .....

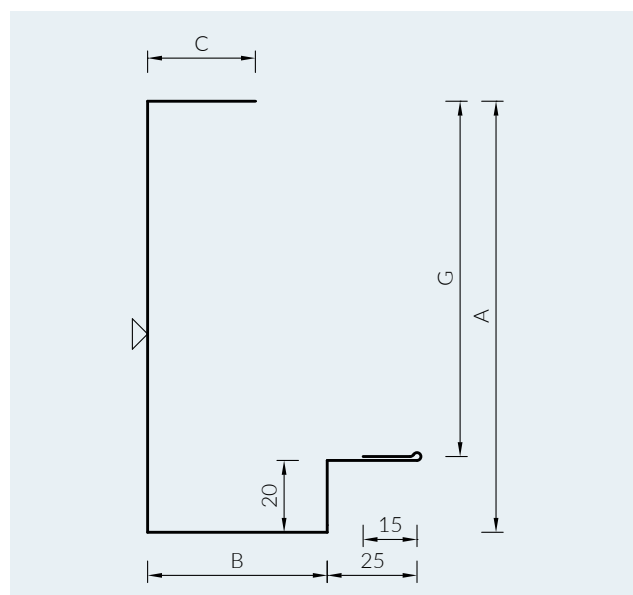

FLASHING 046 - GATE OPENING MASKING FRAME

symbol	A	B	L	area
046/120	120	30	3000 5000 6000	165
046/140	140	30		185
046/160	160	30		205
046/180	180	30		225
046/200	200	30		245
046/220	220	30		265
046/240	240	30		285
046/260	260	30		305

Typical steel sheet thickness 0,50 mm

Untypical steel sheet thickness 0,50 mm or 0,75 mm

046 / A ..... / B .....

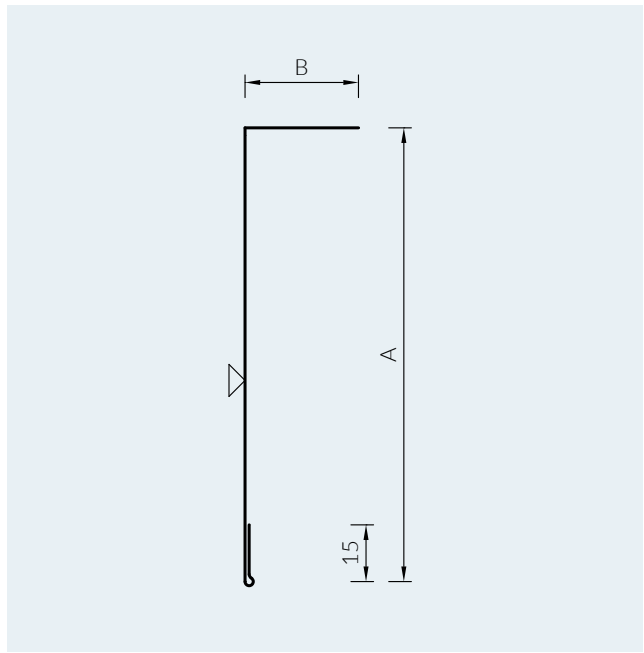

FLASHING 047 - GATE OPENING MASKING FRAME

symbol	A	B	L	area
047/50	50	50	3000 5000	175
047/70	70	50	6000	195

Typical steel sheet thickness 0,50 mm

Untypical steel sheet thickness 0,50 mm or 0,75 mm

047 / A ..... / B .....

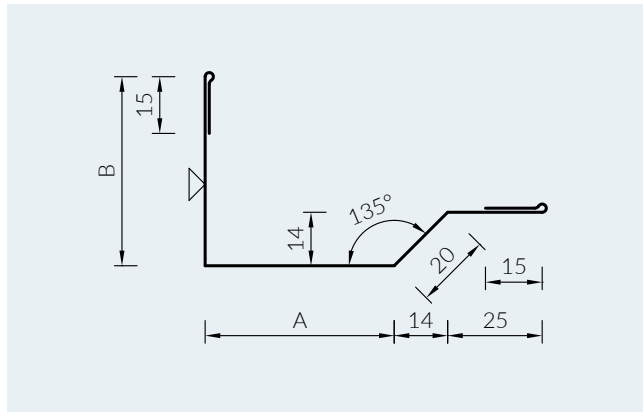

FLASHING 049 - GATE OPENING MASKING FRAME

symbol	A	B	L	area
049/50	50	55	3000 5000	180
049/70	70	55	6000	200

Typical steel sheet thickness 0,50 mm

Untypical steel sheet thickness 0,50 mm or 0,75 mm

049 / A ..... / B .....

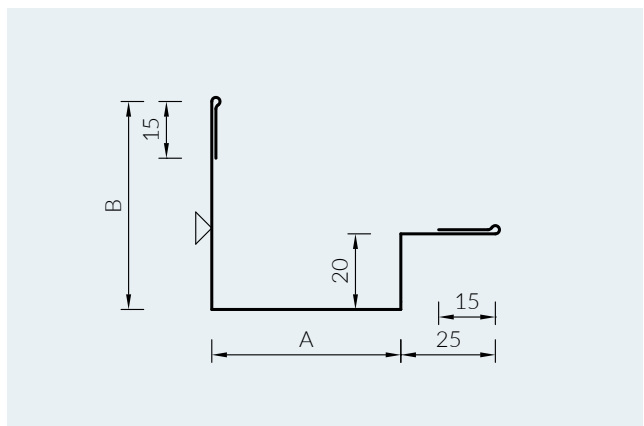

**FLASHING 051 - WINDOW OPENING MASKING FRAME – WINDOWSILL**

symbol	A	L	area
051/50	50	3000	115
051/70	70		135
051/90	90		155
051/110	110	5000	175
051/130	130		195
051/150	150	6000	215
051/200	200		265
051/250	250		315

Typical steel sheet thickness 0,50 mm

Untypical steel sheet thickness 0,50 mm or 0,75 mm

051 / A .....

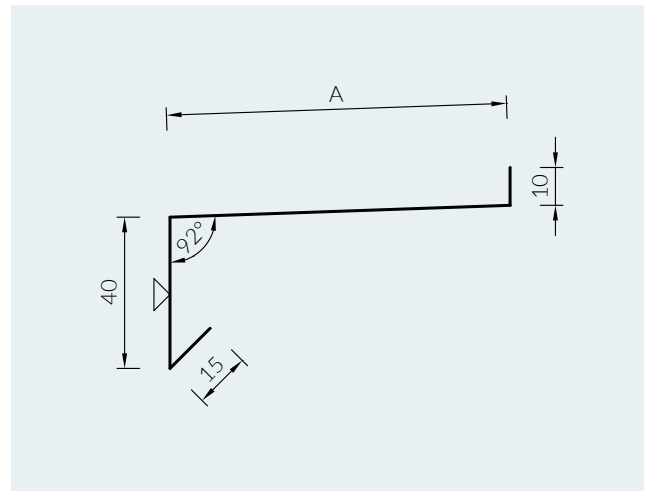

**FLASHING 052 - WINDOW OPENING MASKING FRAME – WINDOWSILL REINFORCEMENT**

symbol	A	B	L	area
052	25	25	3000	65

Typical steel sheet thickness 0,50 mm

Untypical steel sheet thickness 0,50 mm or 0,75 mm

052 / A ..... / B .....

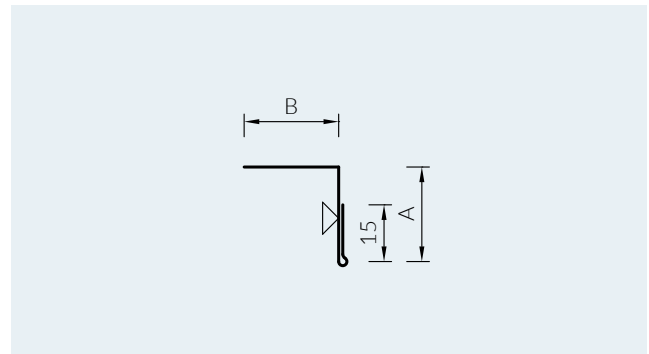

**FLASHING 053 - WINDOW OPENING MASKING FRAME – HEAD**

symbol	A	B	C	L	area
053/40	40	80	30	3000	165
053/60	60				185
053/80	80				205
053/100	100	80	30	6000	225

Typical steel sheet thickness 0,50 mm

Untypical steel sheet thickness 0,50 mm or 0,75 mm

053 / A ..... / B ..... / C .....

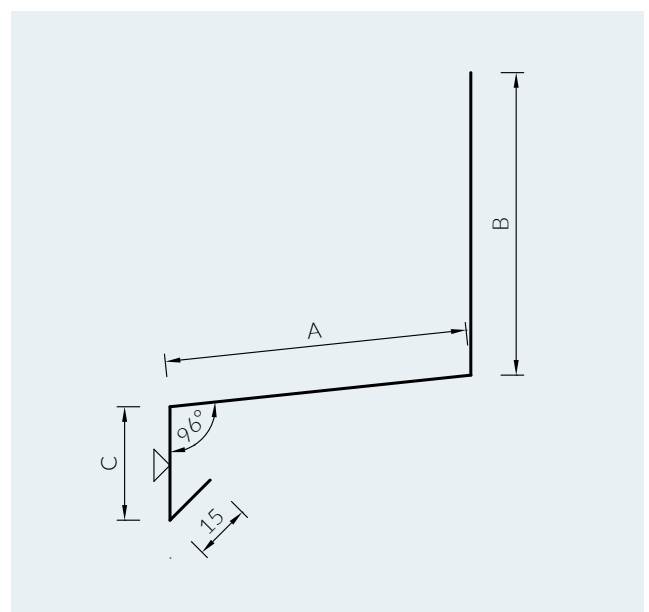

**FLASHING 054 B - WINDOW OPENING MASKING FRAME – HEAD**

symbol	A	B	L	area
054B/40	40	20	3000	75
054B/60	60	20		95

Typical steel sheet thickness 0,50 mm

Untypical steel sheet thickness 0,50 mm or 0,75 mm

054B / A ..... / B .....

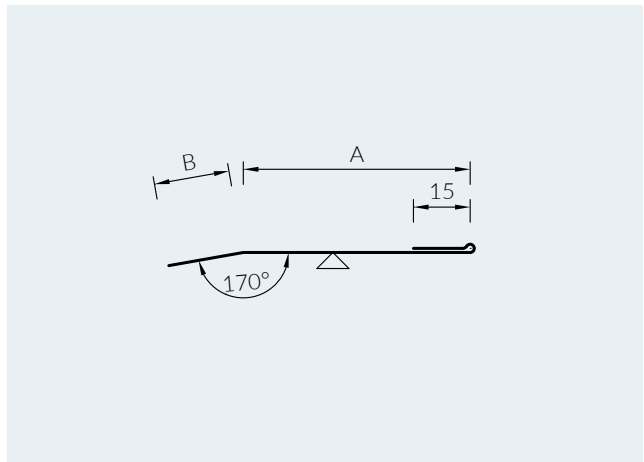

**FLASHING 055 B - WINDOW OPENING MASKING FRAME – EXTERNAL POST**

symbol	A	B	C	L	area
055B/22	22	30	25	3000	107
055B/30	30	30	25		115
055B/35	35	30	25		120
055B/42	42	30	25	3000	127
055B/40	40	30	25		125
055B/60	60	30	25		145
055B/80	80	30	25	5000	165
055B/100	100	30	25	6000	185
055B/120	120	30	25		205

Typical steel sheet thickness 0,50 mm

Untypical steel sheet thickness 0,50 mm or 0,75 mm

055B / A ..... / B ..... / C .....

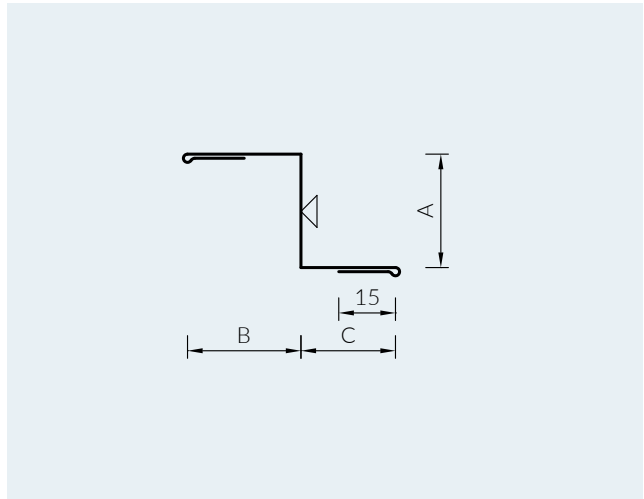

**FLASHING 056 B - WINDOW OPENING MASKING FRAME – EXTERNAL POST**

symbol	A	B	C	L	area
056B/22	22	50	25	3000	186
056B/30	30	50	25		194
056B/35	35	50	25		199
056B/42	42	50	25	5000	206
056B/40	40	50	25		204
056B/60	60	50	25		224
056B/80	80	50	25	6000	244
056B/100	100	50	25		264
056B/120	120	50	25		284

Typical steel sheet thickness 0,50 mm

Untypical steel sheet thickness 0,50 mm or 0,75 mm

056B / A ..... / B ..... / C .....

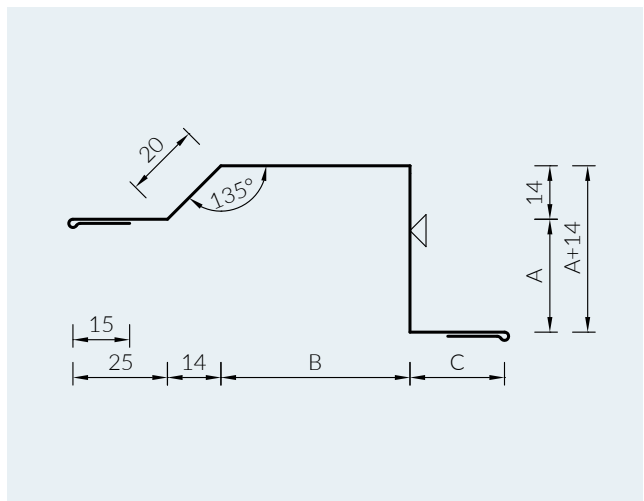

**FLASHING 057 B - WINDOW OPENING MASKING FRAME – EXTERNAL POST**

symbol	A	B	C	L	area
057B/22	22	50	25	3000 5000 6000	192
057B/30	30	50	25		200
057B/35	35	50	25		205
057B/42	42	50	25		212
057B/40	40	50	25		210
057B/60	60	50	25		230
057B/80	80	50	25		250
057B/100	100	50	25		270
057B/120	120	50	25		290

Typical steel sheet thickness 0,50 mm

Untypical steel sheet thickness 0,50 mm or 0,75 mm

057B / A = ..... / B = ..... / C = .....

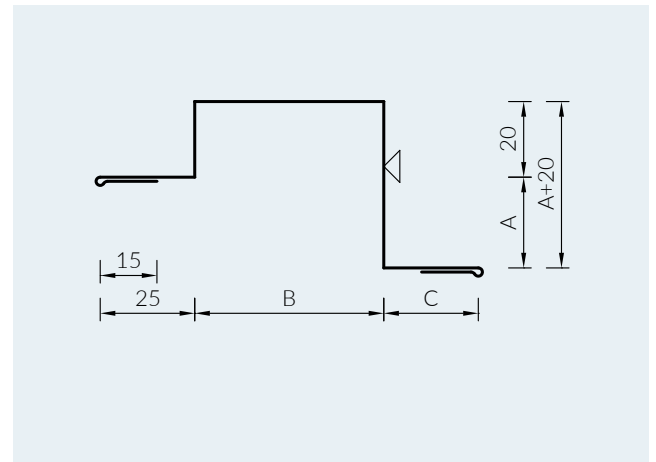

**FLASHING 058 B - WINDOW OPENING MASKING FRAME – INTERNAL FLASHING**

symbol	A	B	L	area
058B/40	40	50	3000 5000 6000	164
058B/60	60	50		184
058B/80	80	50		204
058B/100	100	50		224
058B/120	120	50		244

Typical steel sheet thickness 0,50 mm

Untypical steel sheet thickness 0,50 mm or 0,75 mm

058B / A ..... / B .....

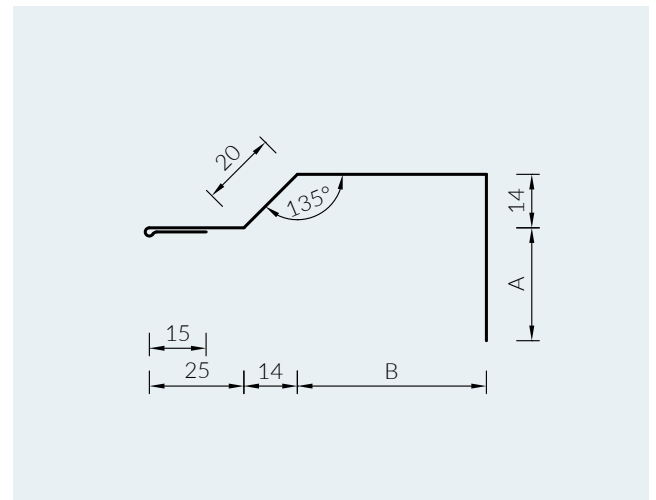

**FLASHING 059 B - WINDOW OPENING MASKING FRAME – INTERNAL FLASHING**

symbol	A	B	L	area
059B/25	25	25	3000	65
059B/30	30	25		70
059B/40	40	25		80

Typical steel sheet thickness 0,50 mm

Untypical steel sheet thickness 0,50 mm or 0,75 mm

059B / A ..... / B .....

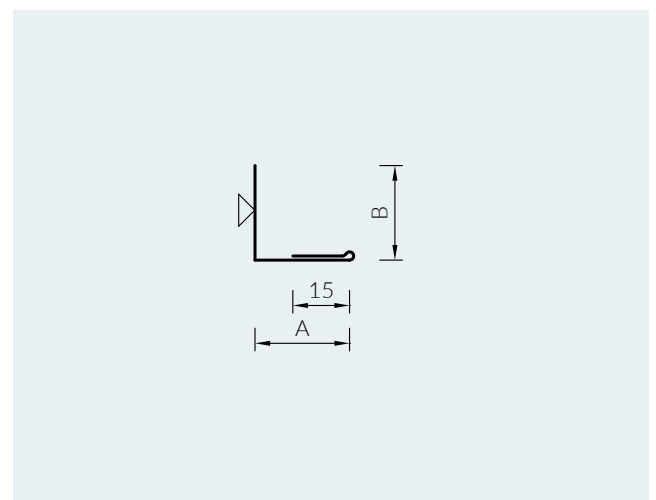

FLASHING 061 - PLINTH FLASHING

symbol	A	B	$\alpha^\circ$	L	area
061	100	50	135	3000 5000 6000	165

Typical steel sheet thickness 0,50 mm  
 Untypical steel sheet thickness 0,50 mm or 0,75 mm  
 061 / A ..... / B ..... /  $\alpha$  .....

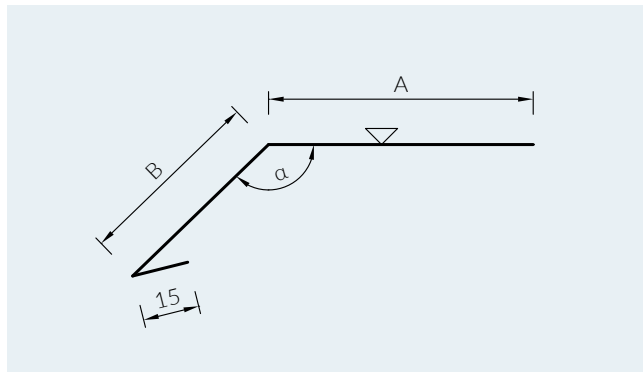

FLASHING 075 - STARTING LIST (HORIZONTAL LAYOUT)

symbol	A	B	L	area
075/40	40	21	3000	61
075/70	70	21		91

Flashing for sandwich panels of type S and CH  
 Typical steel sheet thickness 1,50 mm  
 Untypical steel sheet thickness 1,50 mm  
 075 / A ..... / B .....

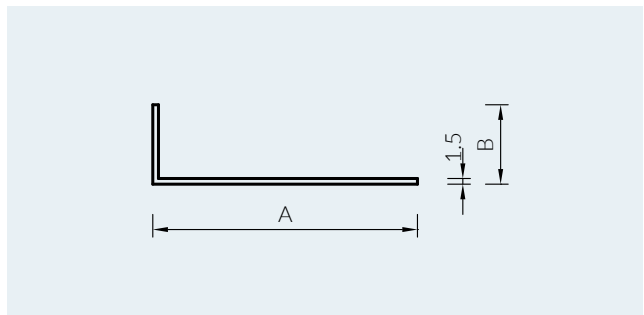

FLASHING 076 - STARTING LIST (HORIZONTAL LAYOUT)

symbol/ panel thk. / type	A	B	C	$\alpha^\circ$	L	area
076/40/S	30	21	60	92	3000	111
076/50/S	40	21	60	92		121
076/60/S	50	21	60	92		131
076/80/S	70	21	60	92		151
076/100/S	90	21	60	92		171
076/120/S	110	21	60	92		191
076/140/S	130	21	60	92		211
076/150/S	140	21	60	92		221
076/160/S	150	21	60	92		231
076/180/S	170	21	60	92		251
076/200/S	190	21	60	92		271
076/60/SU	37	21	60	92		118
076/80/SU	57	21	60	92		138
076/100/SU	77	21	60	92		158
076/120/SU	97	21	60	92		178
076/140/SU	117	21	60	92		198
076/160/SU	137	21	60	92		218
076/180/SU	157	21	60	92		238
076/200/SU	177	21	60	92		258

Flashing denoted with „S” are for sandwich panels of type S and CH  
 Typical steel sheet thickness 1,50 mm  
 Untypical steel sheet thickness 1,50 mm  
 076 / A ..... / B ..... / C ..... /  $\alpha$  .....

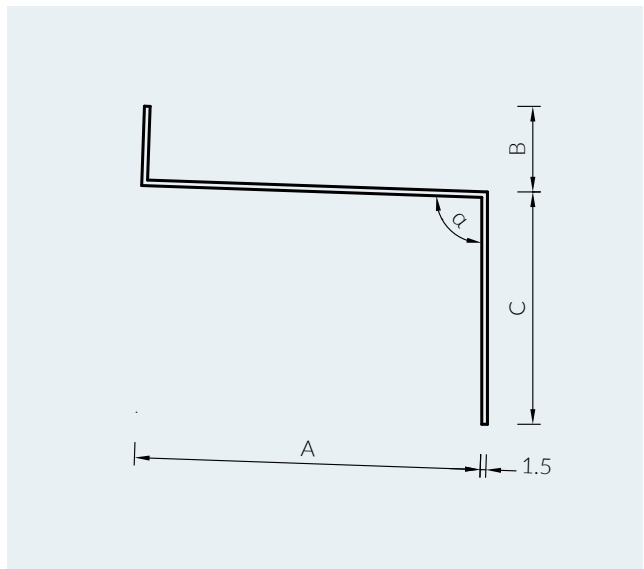



FLASHING 077 - STARTING LIST (HORIZONTAL LAYOUT)

symbol/ panel thk. / type	A	B	C	$\alpha^\circ$	L	area
077/40/S	30	21	60	88	3000	111
077/50/S	40	21	60	88		121
077/60/S	50	21	60	88		131
077/80/S	70	21	60	88		151
077/100/S	90	21	60	88		171
077/120/S	110	21	60	88		191
077/140/S	130	21	60	88		211
077/150/S	140	21	60	88		221
077/160/S	150	21	60	88		231
077/180/S	170	21	60	88		251
077/200/S	190	21	60	88		271
077/60/SU	37	21	60	88		118
077/80/SU	57	21	60	88		138
077/100/SU	77	21	60	88		158
077/120/SU	97	21	60	88		178
077/140/SU	117	21	60	88		198
077/160/SU	137	21	60	88		218
077/180/SU	157	21	60	88		238
077/200/SU	177	21	60	88		258

Flashing denoted with „S“ are for sandwich panels of type S and CH

Typical steel sheet thickness 1,50 mm

Untypical steel sheet thickness 1,50 mm

077 / A ..... / B ..... / C ..... /  $\alpha$  .....

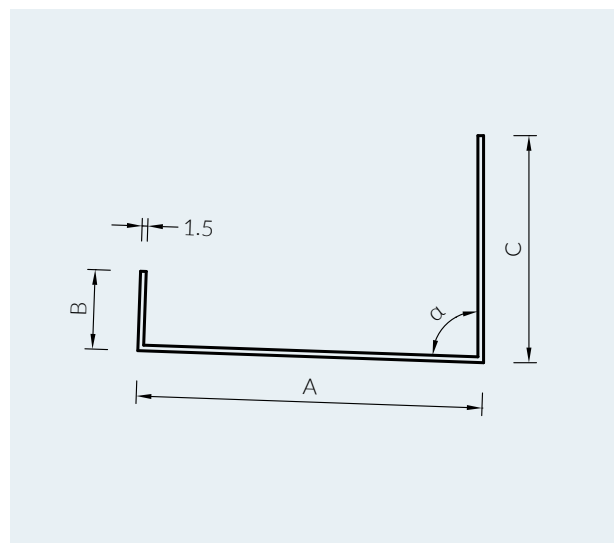

FLASHING 078 - STARTING LIST (HORIZONTAL LAYOUT)

symbol / panel thk.	A	B	L	area
078/80	60	21	3000	102
078/100	80	21		122
078/120	100	21		142
078/140	120	21		162
078/150	130	21		172
078/160	140	21		182
078/180	160	21		202
078/200	180	21		222

Flashing for sandwich panels of type S and CH

Typical steel sheet thickness 1,50 mm

078 / A ..... / B .....

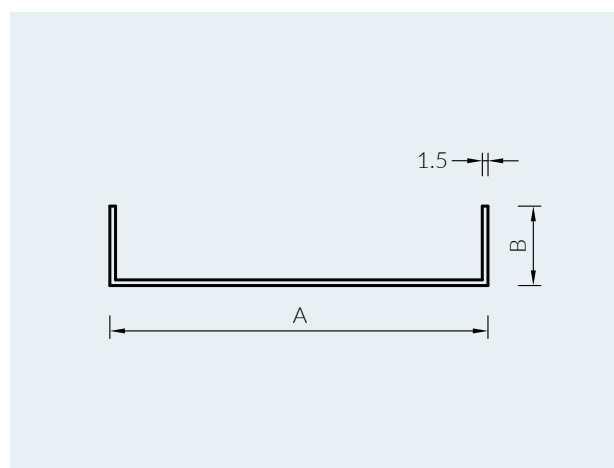



# ROOF PANEL FLASHINGS

FLASHING 101 - UPPER ROOF RIDGE

symbol	A	L	area	slope angle
101/150/α	150	3000 5000 6000	330	$\alpha < 6^\circ$
101/180/α	180		390	$\alpha < 11^\circ$
101/200/α	200		430	$\alpha < 15^\circ$
101/250/α	250		530	$\alpha < 23^\circ$

α - slope angle  
 $\alpha_1 = 180 - 2\alpha$

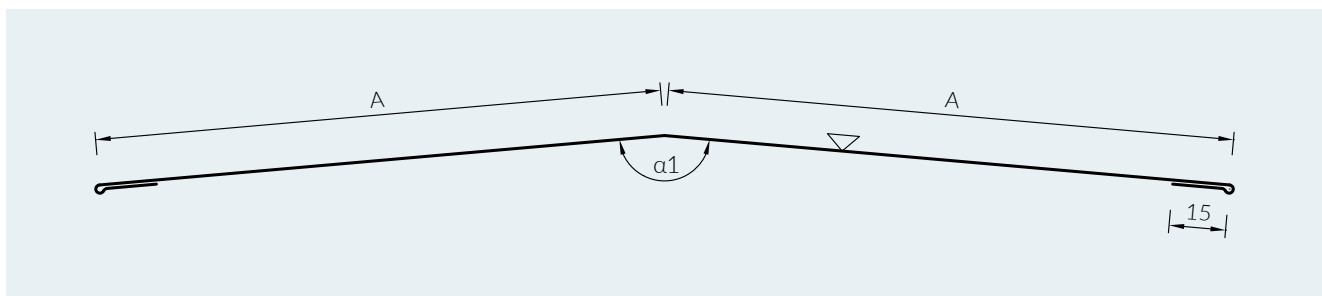

FLASHING 103 - LOWER ROOF RIDGE

symbol	A	L	area
103/50/α	50	3000	130
103/100/α	100	5000	230
103/200/α	200	6000	430

Typical steel sheet thickness 0,50 mm  
 Untypical steel sheet thickness 0,50 mm or 0,75 mm  
 103 / A ..... / α .....

α - slope angle  
 $\alpha_1 = 180 - 2\alpha$

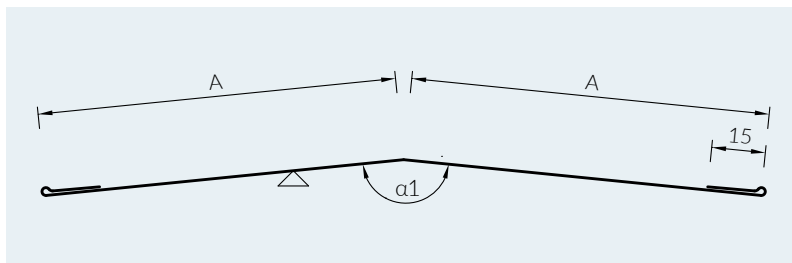

**FLASHING 104 - THE VERGE OF THE SHED ROOF WITHOUT EAVES**

symbol/ panel thk./ $\alpha$	D	A	E	L	area
104/40/ $\alpha$	40	90+x	150	3000 5000 6000	351+x
104/60/ $\alpha$	60	110+x	150		371+x
104/80/ $\alpha$	80	130+x	150		391+x
104/90/ $\alpha$	90	140+x	150		401+x
104/100/ $\alpha$	100	150+x	150		411+x
104/120/ $\alpha$	120	170+x	150		431+x
104/140/ $\alpha$	140	190+x	150		451+x
104/145/ $\alpha$	145	195+x	150		456+x
104/150/ $\alpha$	150	200+x	150		461+x
104/160/ $\alpha$	160	210+x	150		471+x
104/180/ $\alpha$	180	230+x	150		491+x
104/200/ $\alpha$	200	250+x	150		511+x

Typical steel sheet thickness 0,50 mm  
 Untypical steel sheet thickness 0,50 mm or 0,75 mm  
 104 / A ..... / E ..... /  $\alpha$  .....

- D - panel core thickness
- $\alpha$  - slope angle
- x - addition depending on the  $\alpha$  angle
- $\alpha_1 = 90 - \alpha$

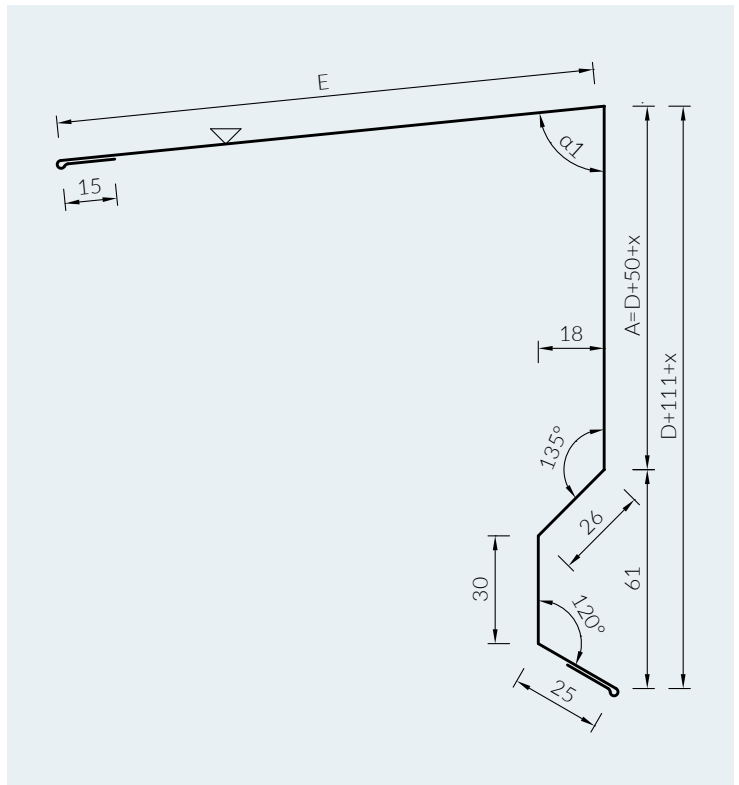

**FLASHING 105 - TOP VERGE OF THE ROOF WITHOUT EAVES**

symbol/ panel thk.	D	A	E	L	area
105/40	40	90	120	3000 5000 6000	393
105/60	60	110	120		413
105/80	80	130	120		433
105/90	90	140	120		443
105/100	100	150	120		453
105/120	120	170	120		473
105/140	140	190	120		493
105/145	145	195	120		498
105/150	150	200	120		503
105/160	160	210	120		513
105/180	180	230	120		533
105/200	200	250	120		553

Typical steel sheet thickness 0,50 mm  
 Untypical steel sheet thickness 0,50 mm or 0,75 mm  
 105 / A ..... / E .....

- D - panel core thickness

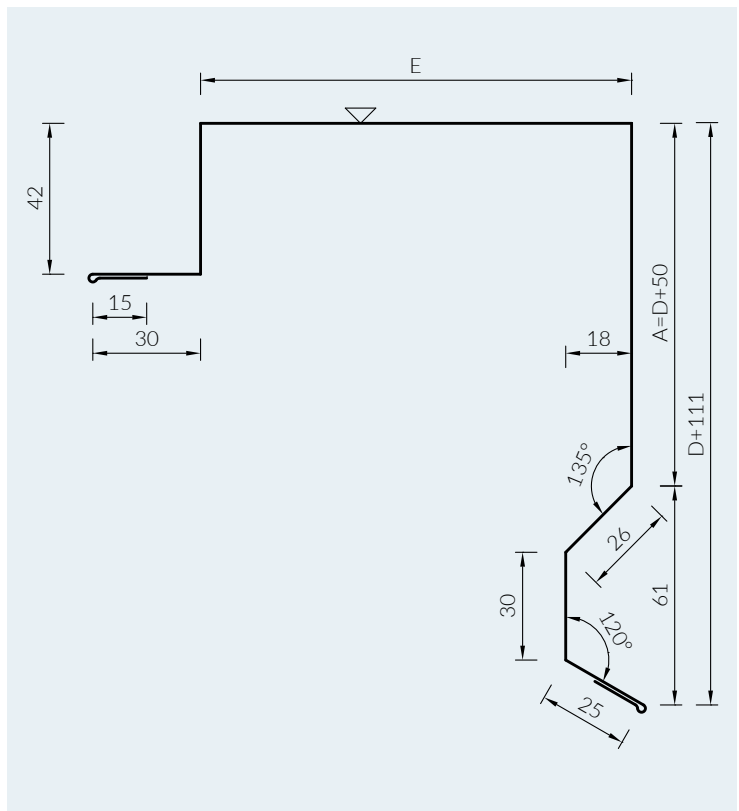

FLASHING 106 - THE VERGE OF THE SHED ROOF WITH EAVES

symbol/ panel thk./α	D	A	E	L	area
106/40/α	40	113+x	150	3000 5000 6000	363+x
106/60/α	60	133+x	150		383+x
106/80/α	80	153+x	150		403+x
106/90/α	90	163+x	150		413+x
106/100/α	100	173+x	150		423+x
106/120/α	120	193+x	150		443+x
106/140/α	140	213+x	150		463+x
106/145/α	145	218+x	150		468+x
106/150/α	150	223+x	150		473+x
106/160/α	160	233+x	150		483+x
106/180/α	180	253+x	150		503+x
106/200/α	200	273+x	150		523+x

Typical steel sheet thickness 0,50 mm  
 Untypical steel sheet thickness 0,50 mm or 0,75 mm  
 106 / D ..... / α .....

α - slope angle  
 x - addition depending on α angle  
 α1 = 90 - α, α2 = 135 - α

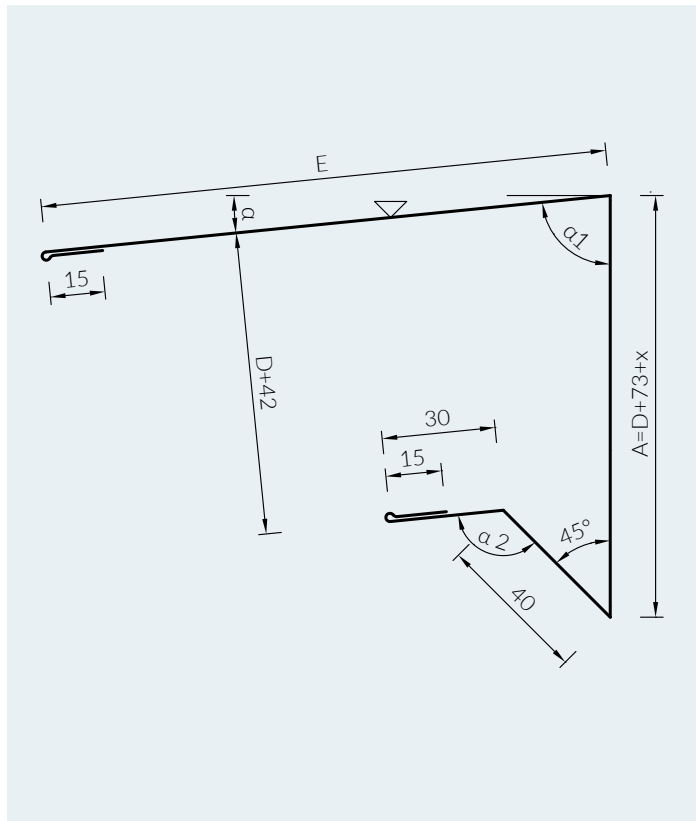

FLASHING 107 - TOP VERGE OF THE ROOF WITH EAVES

symbol/ panel thk./α	D	A	L	area
107/40	40	113	3000 5000 6000	467
107/60	60	133		487
107/80	80	153		507
107/90	90	163		517
107/100	100	173		527
107/120	120	193		547
107/140	140	213		567
107/145	145	218		572
107/150	150	223		577
107/160	160	233		587
107/180	180	253		607
107/200	200	273		627

Typical steel sheet thickness 0,50 mm  
 Untypical steel sheet thickness 0,50 mm or 0,75 mm  
 107 / A .....

D - panel core thickness

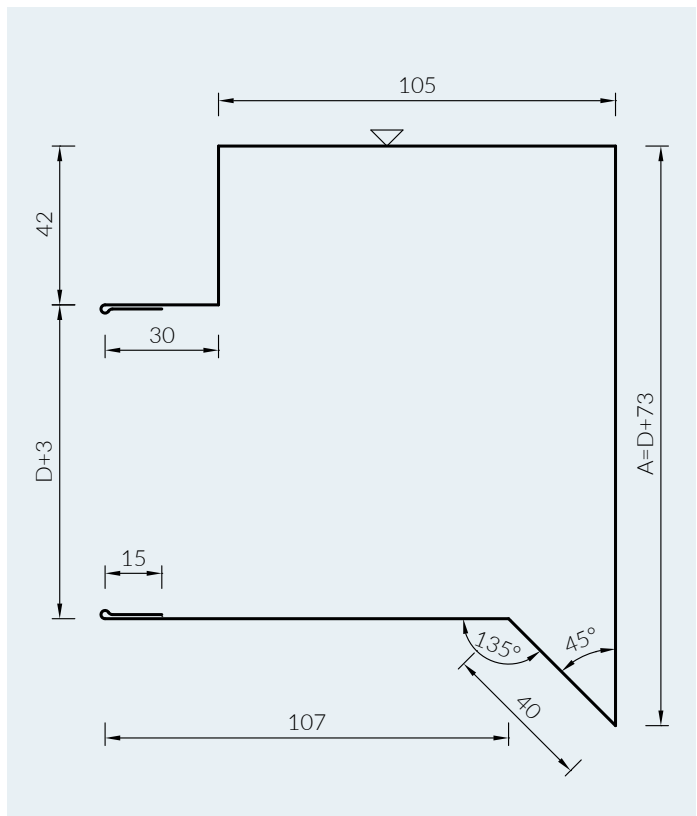

**FLASHING 109 - ROOF MASKING FRAME**

symbol	A	B	L	area
109/60/α	60	100	3000	190
109/80/α	80	100	5000	210
			6000	

Typical steel sheet thickness 0,50 mm

Untypical steel sheet thickness 0,50 mm or 0,75 mm

109 / A ..... / B ..... / α .....

α - slope angle

α1 = 105 + α

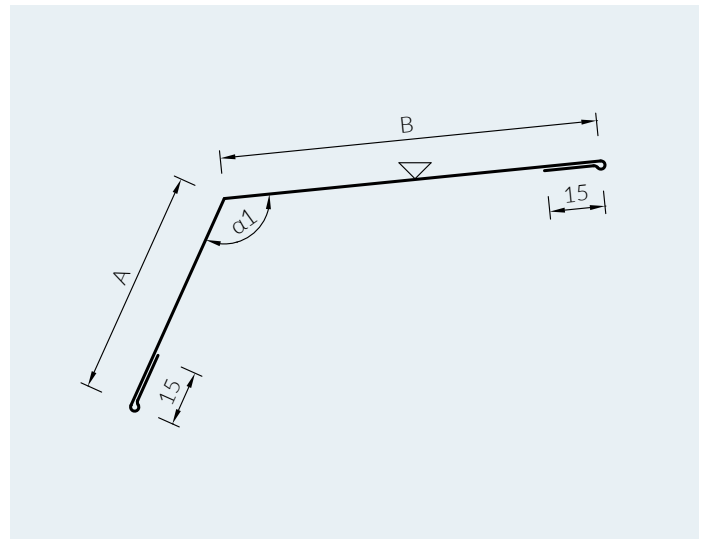

**FLASHING 110 - GUTTER DRIP CAP**

symbol	A	B	L	area
110/40/α	40	40	3000	95
110/60/α	60	40	3000	115
			5000	
110/80/α	80	40	6000	135

Typical steel sheet thickness 0,50 mm

Untypical steel sheet thickness 0,50 mm or 0,75 mm

110 / A ..... / B ..... / α .....

α - slope angle

α1 = 105 + α

Recommended length of section B is 120 mm for eave with 150 flashing

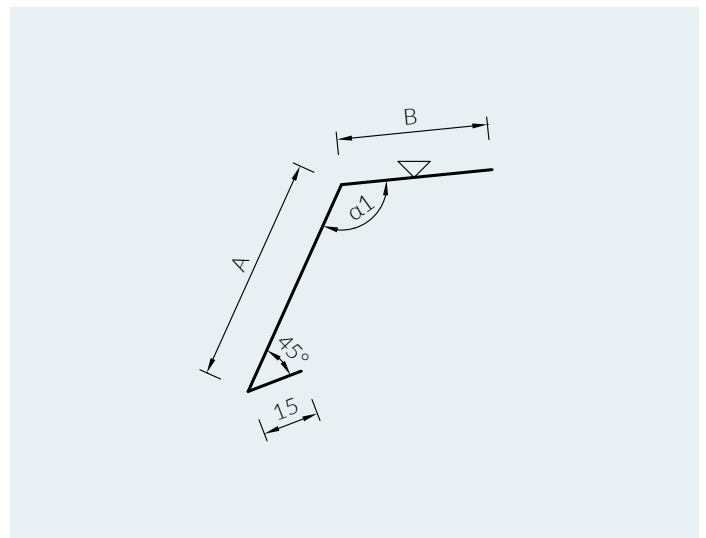

**FLASHING 111 - SNOW HURDLE**

symbol	L	area
111/050	2500	279

Typical steel sheet thickness 0,50 mm

symbol	L	area
111/075	2500	279

Typical steel sheet thickness 0,75 mm

RAL 7016, 7035, 8017, 9002, 9010, 9006

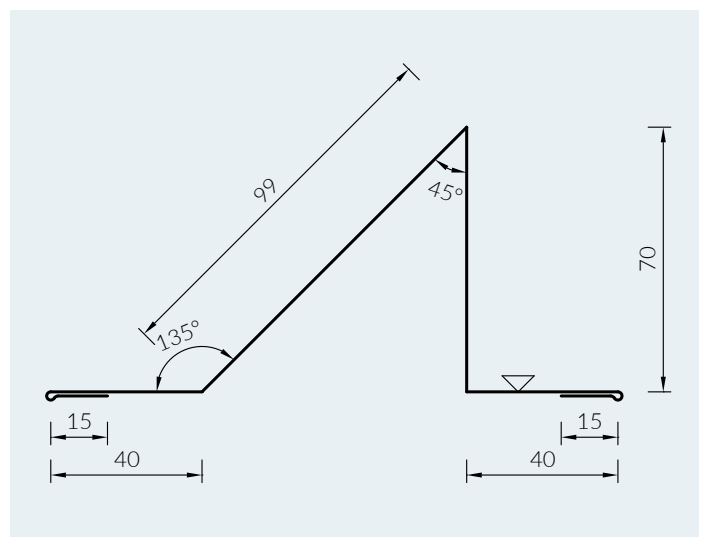

FLASHING 112 - ATTIC FLASHING

symbol/ panel thk./a	D	A	L	area
112/40	40	71	3000 5000 6000	324
112/50	50	81		334
112/60	60	91		344
112/80	80	111		364
112/100	100	131		384
112/120	120	151		404
112/140	140	171		424
112/150	150	181		434
112/160	160	191		444
112/180	180	211		464
112/200	200	231	484	

Typical steel sheet thickness 0,50 mm  
 Untypical steel sheet thickness 0,50 mm or 0,75 mm  
 112 / D .....  
 D - panel core thickness

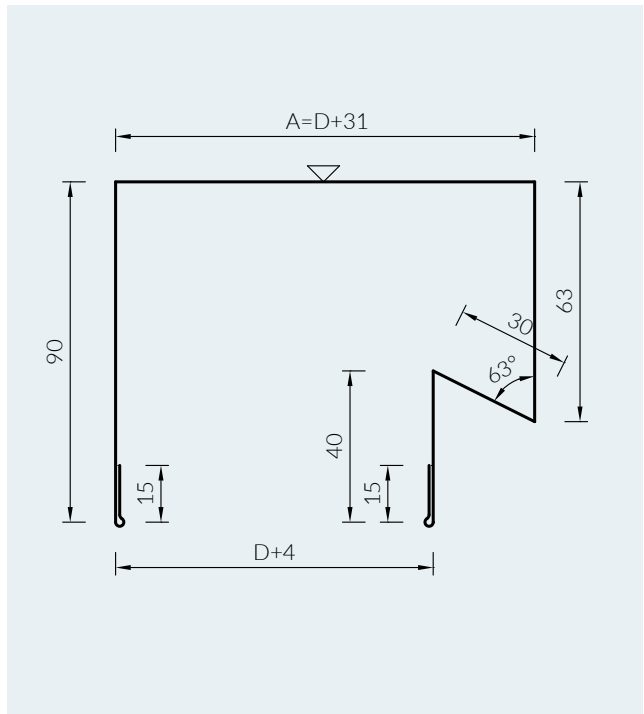

FLASHING 113 - ATTIC FLASHING WITH DRIP CAP

symbol/ panel thk./a	D	A	L	area
113/40	40	59	3000 5000 6000	317
113/50	50	69		327
113/60	60	79		337
113/80	80	99		357
113/100	100	119		377
113/120	120	139		397
113/140	140	159		417
113/150	150	169		427
113/160	160	179		437
113/180	180	199		457
113/200	200	219	477	

Typical steel sheet thickness 0,50 mm  
 Untypical steel sheet thickness 0,50 mm or 0,75 mm  
 113 / D .....  
 D - panel core thickness

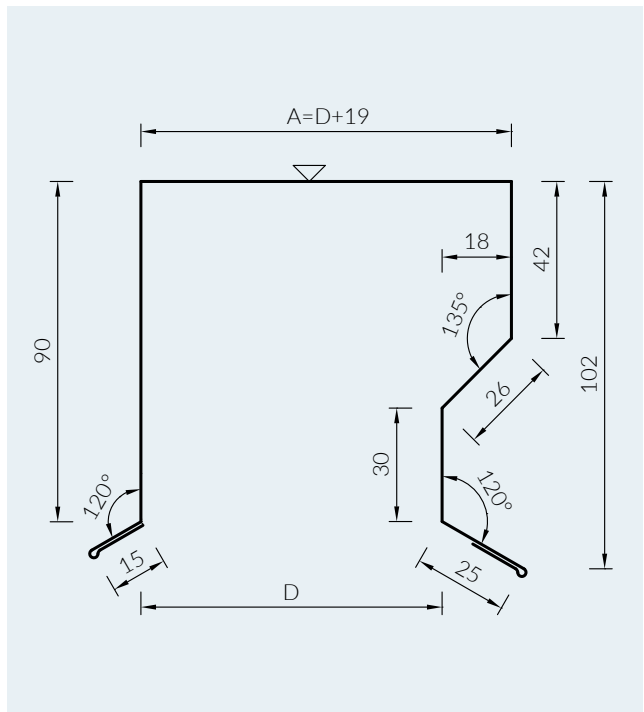



**FLASHING 114 - SLOPE MASKING FRAME  
(THE JOINT BETWEEN PANEL AND ATTIC WALL)**

symbol	A	B	L	area
114/100/α	150	100	3000 5000 6000	280
114/150/α	150	150		330
114/200/α	150	200		380
114/250/α	150	250		430
114/300/α	150	300		480

Typical steel sheet thickness 0,50 mm

Unotypical steel sheet thickness 0,50 mm or 0,75 mm

114 / A ..... / B ..... / α .....

α - slope angle

α1 = 90 + α

α = 0 - for the flashing situated along the slope

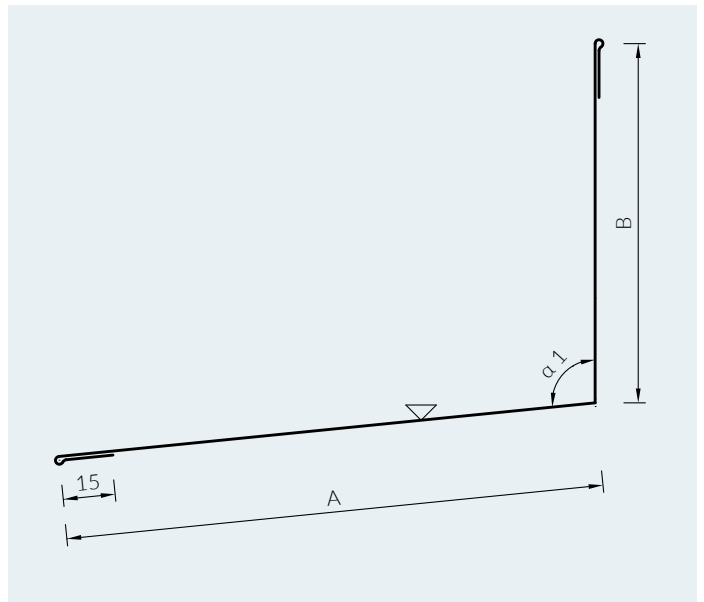

**FLASHING 115 - SLOPE MASKING FRAME  
(THE JOINT WITH THE BRICK WALL)**

symbol	A	B	L	area
115/100/α	150	100	3000 5000 6000	275
115/150/α	150	150		325
115/200/α	150	200		375
115/250/α	150	250		425
115/300/α	150	300		475

Typical steel sheet thickness 0,50 mm

Unotypical steel sheet thickness 0,50 mm or 0,75 mm

115 / A ..... / B ..... / α .....

α - slope angle

α1 = 90 + α

α = 0 - for the flashing situated along the slope

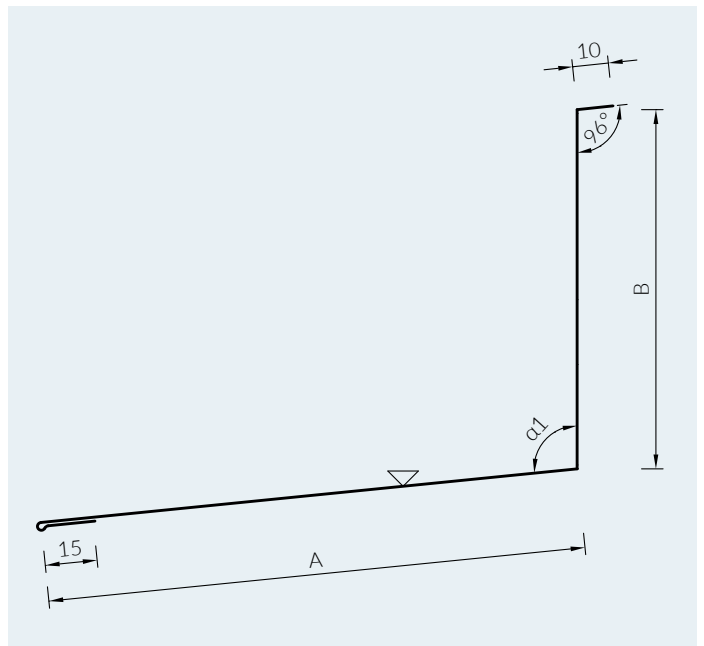

**FLASHING 116 - SLOPE MASKING FRAME  
(THE JOINT WITH ATTIC WALL SANDWICH PANEL)**

symbol	A	B	L	area
116/100/α	110	100	3000 5000 6000	245
116/150/α	110	150		295
116/200/α	110	200		345
116/250/α	110	250		395
116/300/α	110	300		445

Typical steel sheet thickness 0,50 mm

Unotypical steel sheet thickness 0,50 mm or 0,75 mm

116 / A ..... / B .....

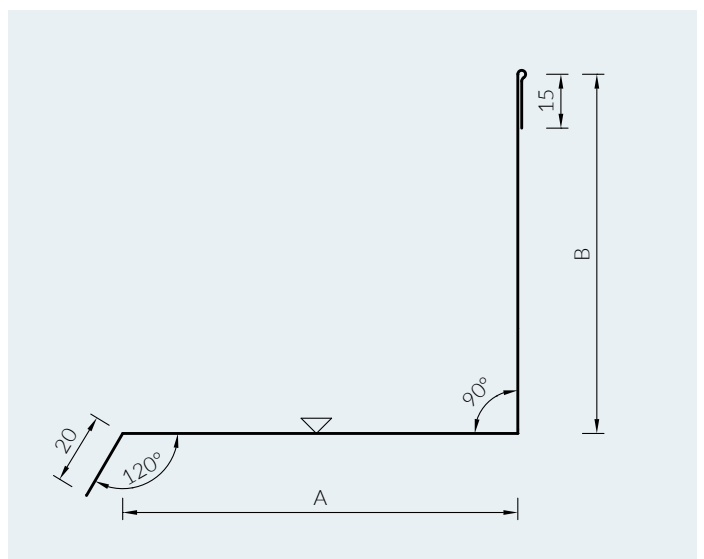

FLASHING 117B

symbol	A	B	C	D	$\alpha^\circ$	L	area
117B/100	50	110	42	100	90	3000	332
117B/150	50	110	42	150	90		382
117B/200	50	110	42	200	90	5000	432
117B/250	50	110	42	250	90	6000	482
117B/300	50	110	42	300	90		532

Typical steel sheet thickness 0,50 mm

Untypical steel sheet thickness 0,50 mm or 0,75 mm

117B / A ..... / B ..... / C ..... / D ..... /  $\alpha$  .....

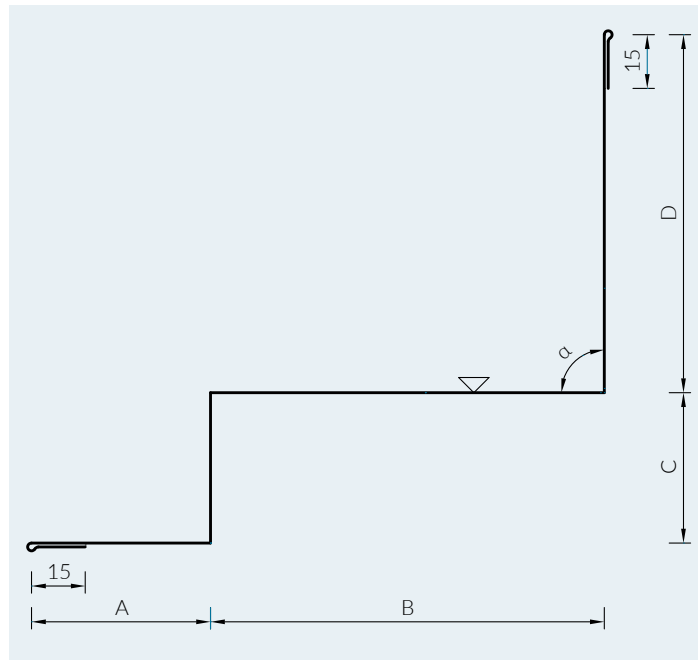

FLASHING 118 - SANDWICH PANEL DRIP CAP

symbol	L	area
118	3000	125

Typical steel sheet thickness 0,50 mm

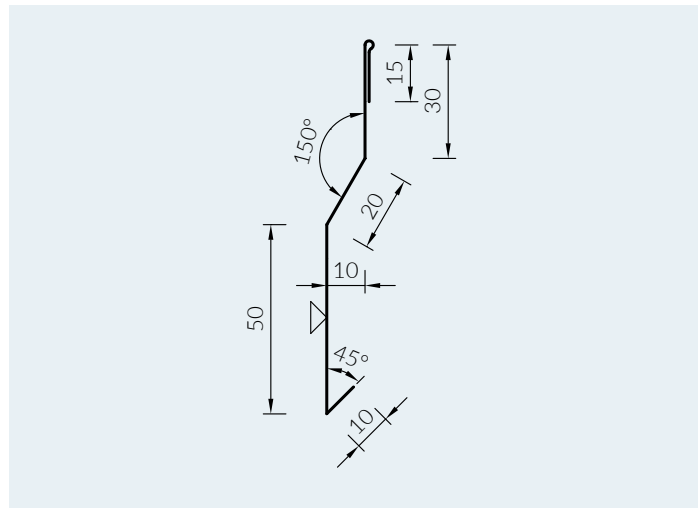

FLASHING 119 - BRICK WALL DRIP CAP

symbol	L	area
119	3000	120

Typical steel sheet thickness 0,50 mm

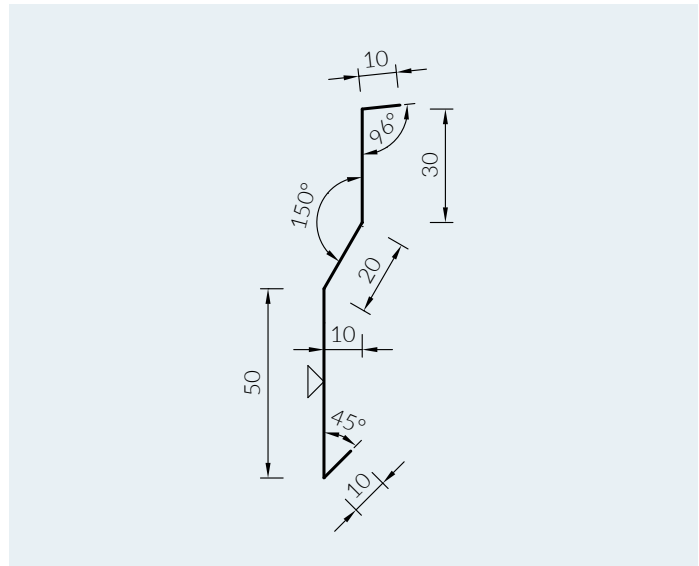

FLASHING 121 - LIST OF SLOPE MASKING FRAME 114 OR 115 SITUATED ALONG THE ROOF SLOPE

symbol	L	area
121	3000	150
	5000	
	6000	

Typical steel sheet thickness 0,50 mm

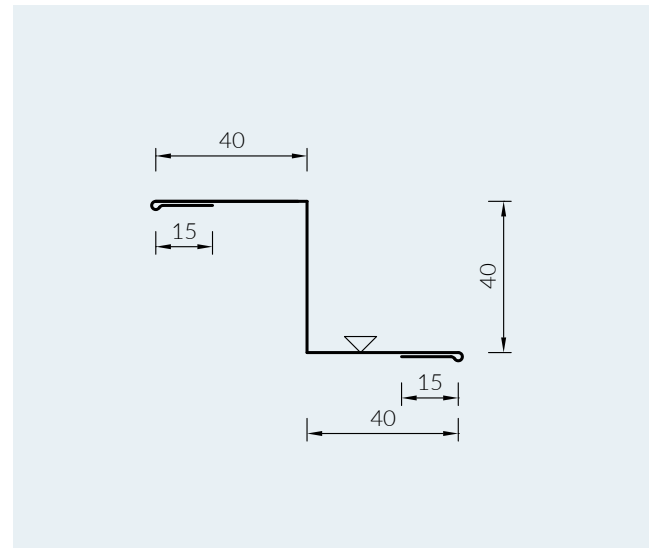

FLASHING 130 - GUTTER Z-BAR

symbol/ panel thk./ $\alpha$	D	C	L	area
130/40/ $\alpha$ *	40	50	3000 5000 6000	130+x
130/60/ $\alpha$ *	60	50		150+x
130/80/ $\alpha$ *	80	50		170+x
130/90/ $\alpha$ *	90	50		180+x
130/100/ $\alpha$	100	50		190+x
130/120/ $\alpha$	120	50		210+x
130/140/ $\alpha$	140	50		230+x
130/145/ $\alpha$	145	50		235+x
130/150/ $\alpha$	150	50		240+x
130/160/ $\alpha$	160	50		250+x
130/180/ $\alpha$	180	50		270+x
130/200/ $\alpha$	200	50		290+x

Typical unpainted steel sheet, thickness 1,50 mm

Unypical steel sheet painted (RAL 9010), thickness 1,50 mm

130 / A ..... / C ..... /  $\alpha$  .....

$\alpha$  - slope angle,  $\alpha_1 = 90 - \alpha$

D - panel core thickness, x - addition depending on  $\alpha$  angle

With roof inclination  $>10^\circ$ , according to panel thickness, extend section C

\* - not recommended for panel thickness D=40-90mm

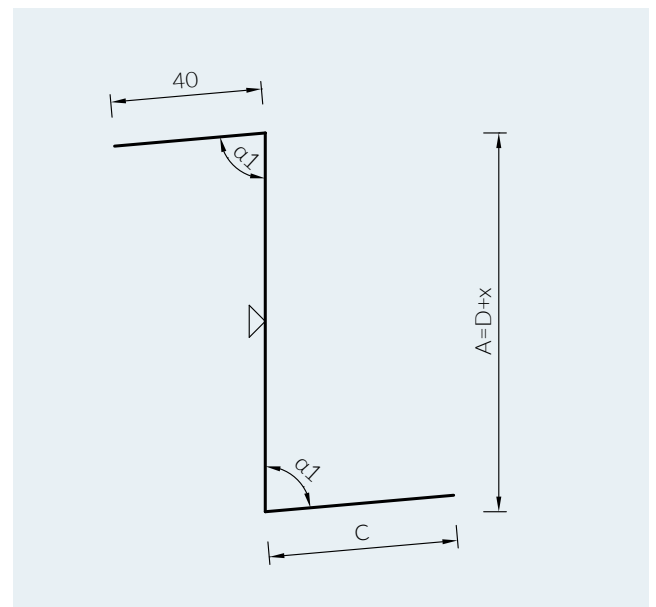

FLASHING 131 - EXTENDED GUTTER Z-BAR

symbol/ panel thk./α	D	B	C	L	area
131/40/α	40	70	50	3000 5000 6000	285+x
131/60/α	60	50	50		265+x
131/80/α	80	30	50		245+x
131/90/α	90	30	50		255+x
131/100/α	100	30	50		265+x
131/120/α	120	30	50		285+x
131/140/α	140	30	50		305+x
131/145/α	145	30	50		310+x
131/150/α	150	30	50		315+x
131/160/α	160	30	50		325+x
131/180/α	180	30	50		345+x
131/200/α	200	30	50		365+x

Typical steel sheet thickness 0,75 mm  
(RAL 7016, 7035, 8017, 9002, 9010, 9006)

Untypical steel sheet thickness 0,75 mm  
(RAL 7035, 8017, 9002, 9010, 9006)

131 / A ..... / B ..... / C ..... / α .....

α - slope angle, α1 = 90 - α, α2 = 90 + α

D - panel core thickness, x - addition depending on α angle

With roof inclination >10°, according to panel thickness,  
extend section C

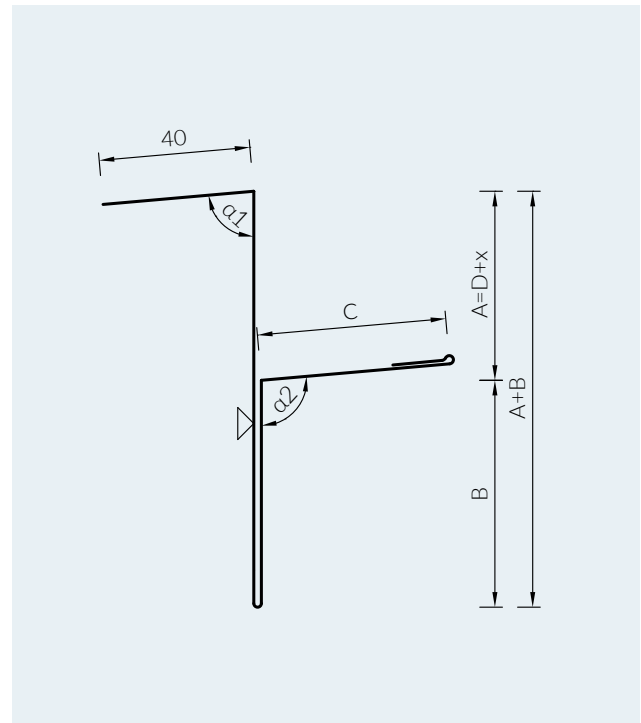

FLASHING 150 - GUTTER CHANNEL

symbol/ panel thk./α	D	C	L	area
150/40/α	40	50	3000 5000 6000	130+x
150/60/α	60	50		150+x
150/80/α	80	50		170+x
150/90/α	90	50		180+x
150/100/α	100	50		190+x
150/120/α	120	50		210+x
150/140/α	140	50		230+x
150/145/α	145	50		235+x
150/150/α	150	50		240+x
150/160/α	160	50		250+x
150/180/α	180	50		270+x
150/200/α	200	50		290+x

Typical unpainted steel sheet, thickness 1,50 mm

Untypical steel sheet painted (RAL 9010), thickness 1,50 mm  
(RAL 9010) gr. 1,50 mm

150 / A ..... / B ..... / C ..... / α .....

α - slope angle, α1 = 90 - α, α2 = 90 + α

D - panel core thickness, x - addition depending on α angle

With roof inclination >10°, according to panel thickness,  
extend section C

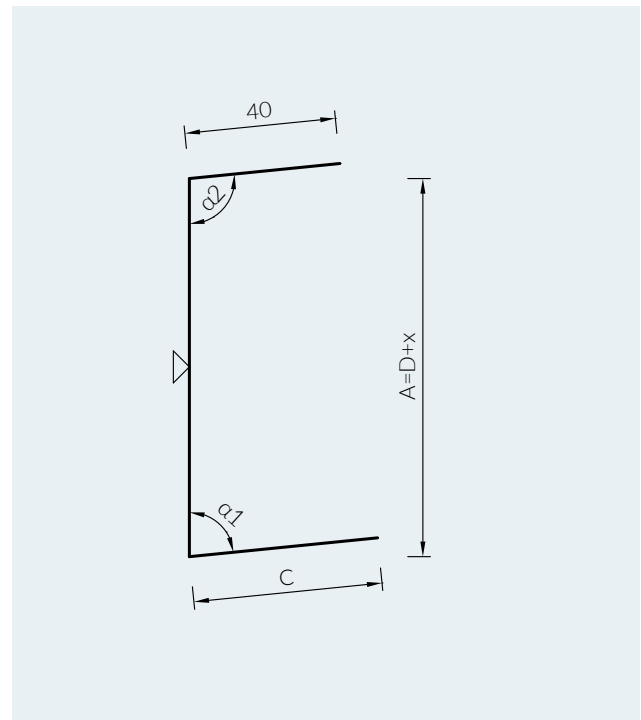





# ACCESSORIES

**FLASHING 102**

installation in ridge, 1 piece per panel

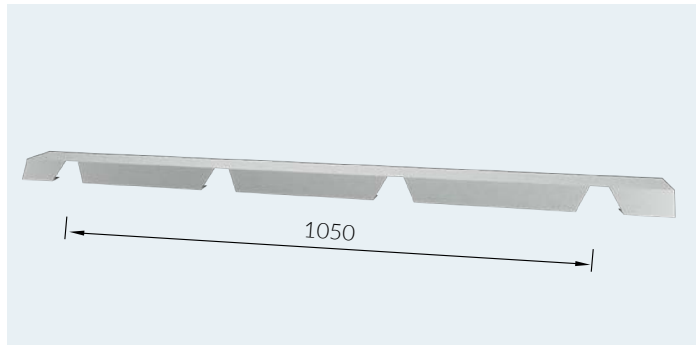

**UD42 RIDGE ROOF SEAL**

installation in ridge, 1 piece per panel

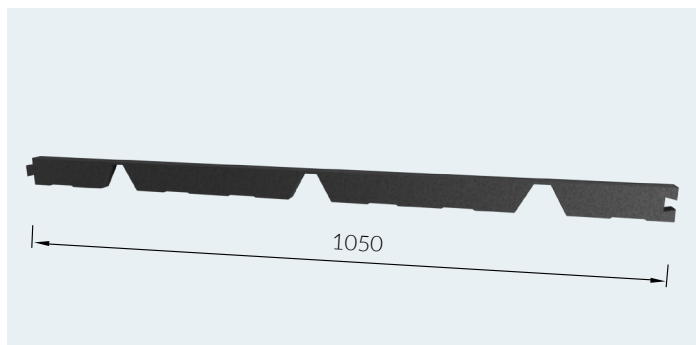

**ROOF END CAP Z42**

installation in eave, 3 pieces per panel

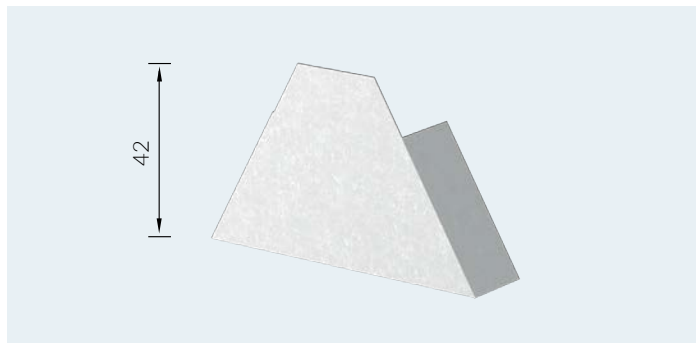

**SU WASHER**

installation in panel with hidden joint SU

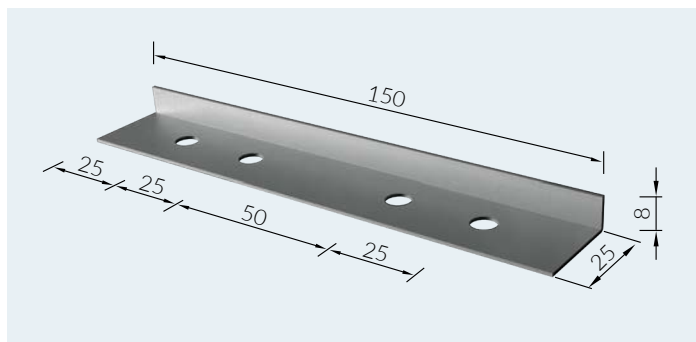

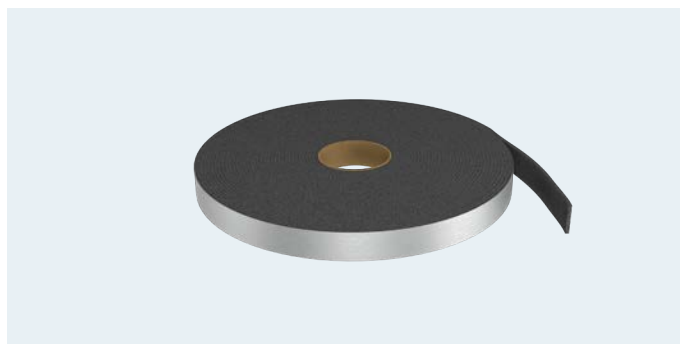
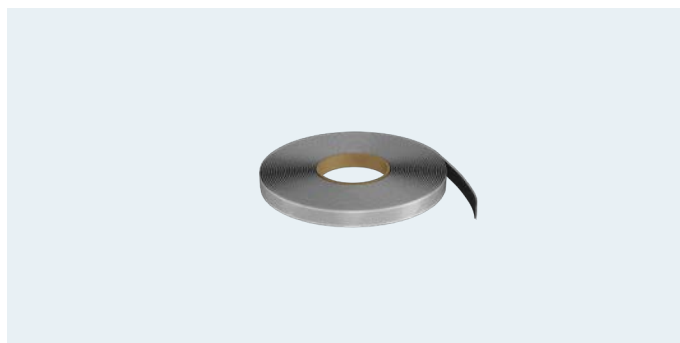

**SOUNDPROOFING TAPE - ADHESIVE SEAL****TA-30:** 30 x 3 mm x 30 m**TA-50:** 50 x 3 mm x 30 m**EXPANDING ADHESIVE POLYURETHANE TAPE****TR-20x10:** 20 x 10 mm x 8 m**TR-20x20:** 20 x 20 mm x 8 m**TR-50x20:** 50 x 20 mm x 8 m**BUTYL TAPE - WATERPROOFING SEALING COMPOUND****TB-15x1,5:** 15 x 1,5 mm x 25 m

**BUTYL SEALANT - WATERPROOFING SEALING COMPOUND**

**UB-600:** 600 mL foil sleeve

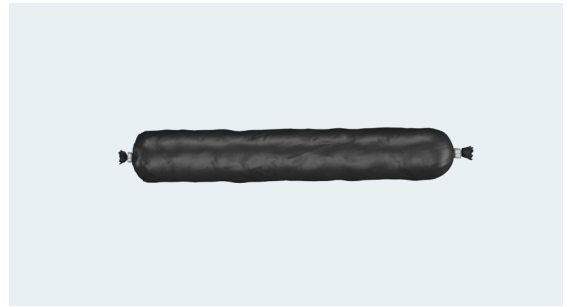

**SILICONE SEALANT - WATERPROOFING SEALING COMPOUND**

**US-300:** 300 mL cartridge



**SILICONE SEALANT - WATERPROOFING SEALING COMPOUND**

**UB-600:** 600 mL foil sleeve

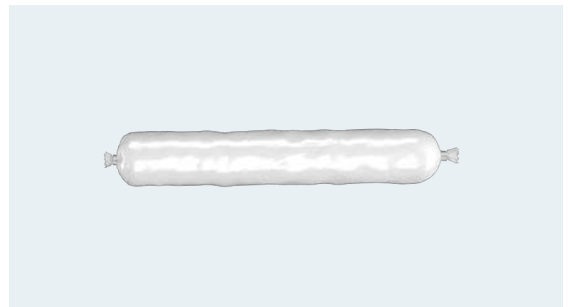

**FIRE BARRIER PROMASEAL- MASTIC  
OR PROMASEAL - A**

**O-PM:** 310 mL cartridge

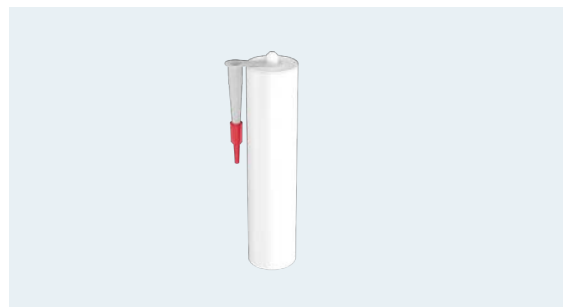

**LOW-PRESSURE ASSEMBLY FOAM**

**PM-750:** 750 mL spray can

**PM-850:** 850 mL spray can



SELF-DRILLING FASTENER WITH Ø 19 MM EPDM WASHER - FIXING SANDWICH PANELS TO STEEL STRUCTURE OF 1 ÷ 5 MM IN THICKNESS

**LS-w5:** Ø 5,5/6,3 x 80 ÷ 240 mm

**LS-w5-N:** Ø 5,5/6,3 x 80 ÷ 240 mm (stainless)

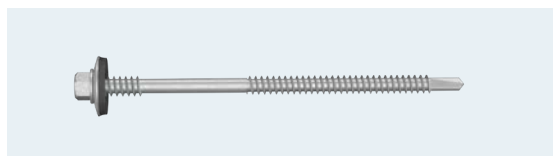

SELF-DRILLING FASTENER WITH Ø 19 MM EPDM WASHER - FIXING SANDWICH PANELS TO STEEL STRUCTURE OF 4 ÷ 12 MM IN THICKNESS

**LS-w12:** Ø 5,5/6,3 x 80 ÷ 240 mm

**LS-w12-N:** Ø 5,5/6,3 x 80 ÷ 240 mm (stainless)

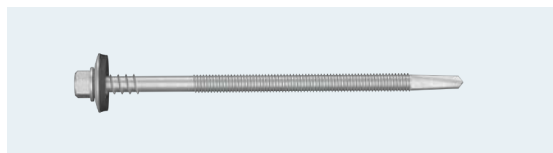

STAINLESS SELF-TAPPING FASTENER WITHOUT DRILL WITH Ø 19 MM EPDM WASHER - FIXING SANDWICH PANELS TO STEEL STRUCTURE OF THICKNESS FROM 7 MM

**LS-w0-N:** Ø 6,3 x 64 ÷ 270 mm (stainless)



PRECISION DRILL FOR LS-WO-N FASTENER

**LS-w0-W:** Ø 5,7 x 170 ÷ 290 mm

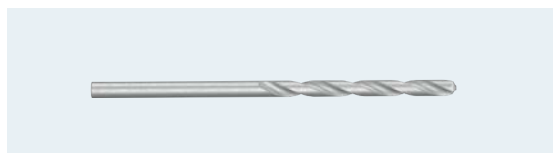

SELF-TAPPING FASTENER WITH Ø 19 MM EPDM WASHER - FIXING SANDWICH PANELS TO CONCRETE STRUCTURE

**LB:** Ømin 6,0 x 100 ÷ 250 mm

**LB-N:** Ømin 6,0 x 100 ÷ 250 mm (stainless)



SELF-TAPPING FASTENER WITH Ø 19 MM EPDM WASHER - FIXING SANDWICH PANELS TO WOODEN STRUCTURE

**LD:** Ømin 6,0 x 90 ÷ 300 mm

**LD-N:** Ømin 6,0 x 90 ÷ 300 mm (stainless)

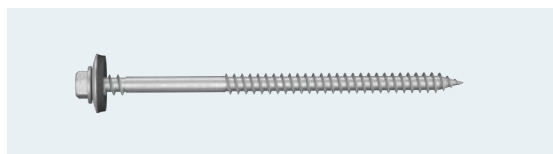

SELF-DRILLING FARMER SCREW WITH EPDM WASHER - FIXING FLASHINGS AND STITCHING ROOF PANELS

**WSF:** Ø 4,8 x 16 ÷ 55 mm

**WSF-N:** Ø 4,8 x 16 ÷ 55 mm (stainless)

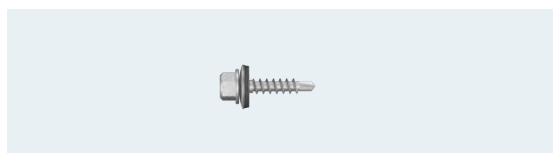

SELF-DRILLING WASHER HEAD SCREW (WITHOUT EPDM) - FIXING FLASHINGS

**WSP:** Ø 4,2 x 13 ÷ 25 mm

**WSP-N:** Ø 4,2 x 13 ÷ 25 mm (stainless)

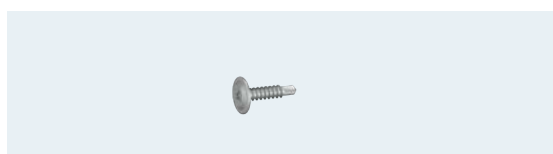

LAX CLIP WITH EPDM WASHER, SUITABLE FOR USE WITH SWAL FASTENERS WITH Ø 16 MM EPDM WASHER

LAX: Ø 45 x 23 x 33 mm

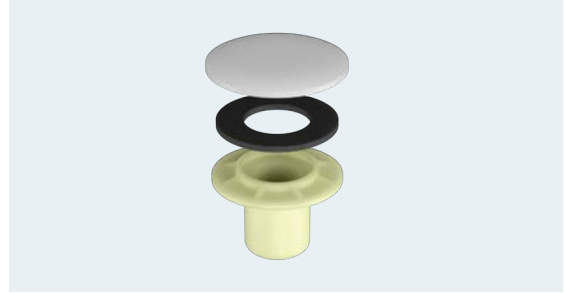

SWAL SELF-DRILLING FASTENER WITH Ø 16 MM EPDM WASHER - FIXING SANDWICH PANELS TO STEEL STRUCTURE

LAX LS-w6: Ø 5,5/6,3 x 70 ÷ 230 mm (for structure thk. of 2 ÷ 5 mm)

LAX LS-w14: Ø 5,5/6,3 x 65 ÷ 230 mm (for structure thk. of 4 ÷ 13 mm)



SWAL SELF-TAPPING FASTENER WITH Ø 16 MM EPDM WASHER - FIXING SANDWICH PANELS TO CONCRETE OR WOODEN STRUCTURE

LAX LBD: Ø 5,5/6,3 x 70 ÷ 260 mm



BLIND RIVET FOR FIXING FLASHINGS

NZ: Ø 4 x 12 mm

NZ-N: Ø 4 x 12 mm (stainless)

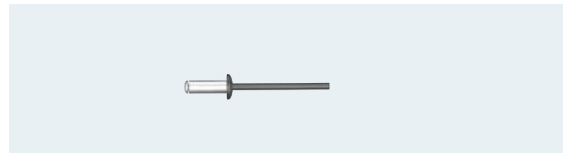

CAP - ALUMINIUM WASHER WITH EPDM

KT: 25 x 40 mm

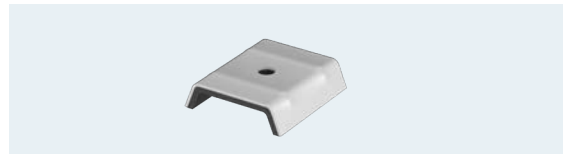

MASKING CLIP FOR 8 MM FASTENER HEAD

KP: Ø 19 mm

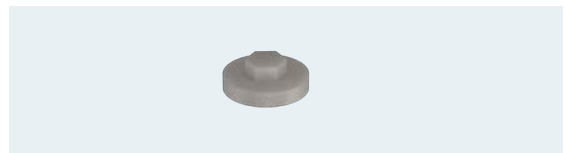

The technical solutions presented in this Technical Catalog are for reference only and require further consultations with the designer.

Paneltech hereby waives any responsibility for errors resulting from the incorrect use of information presented in this Catalog. The catalog shall not constitute an offer within the meaning of the Civil Code. Paneltech Sp. z o.o. reserves the right to introduce changes without notification.

The Performance Declaration and the General Sales Conditions are also available on our website [www.paneltech.eu](http://www.paneltech.eu).











PaNELTECH Sp. z o.o.  
41-508 Chorzów  
ul. Michałkowicka 24  
+48 32 245 91 41  
info@paneltech.pl

---

**PANELTECH.EU**